

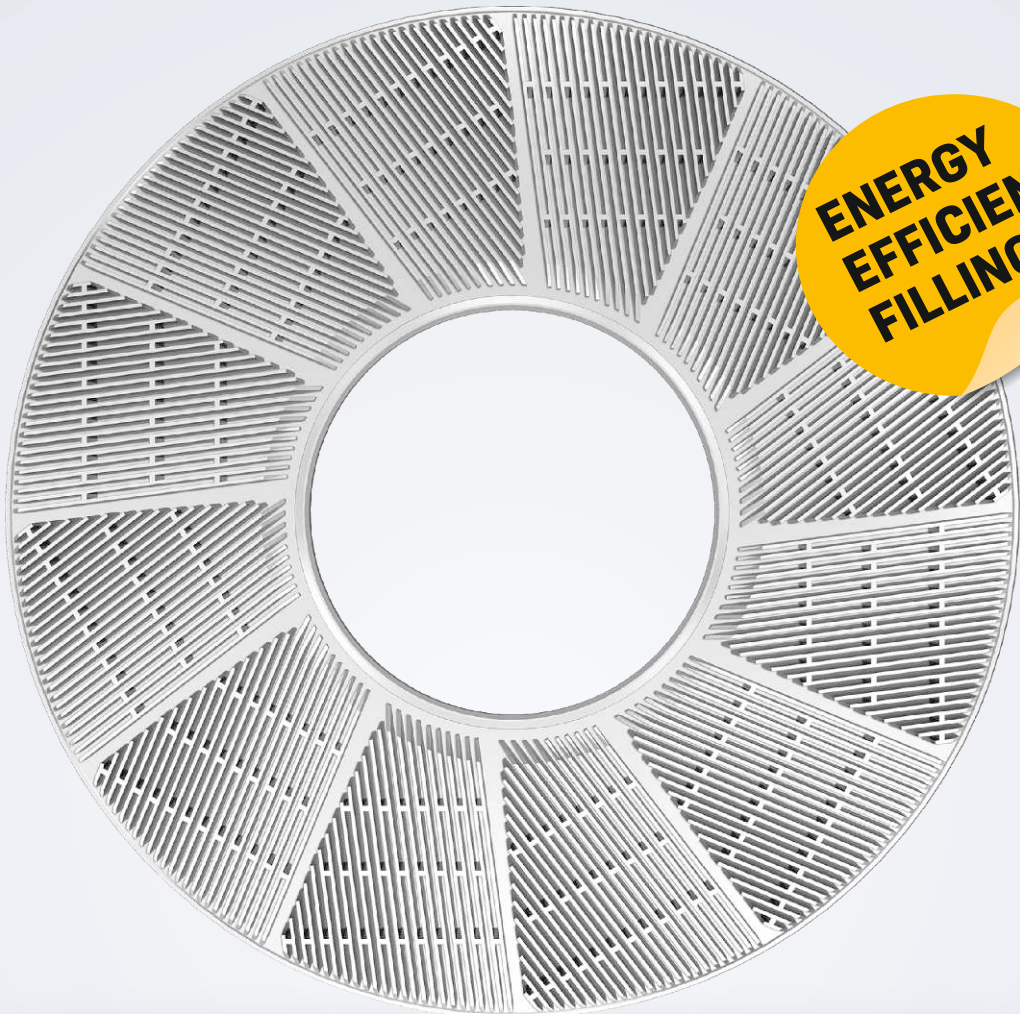

PARASON

www.parason.com



**ENERGY
EFFICIENT
FILLINGS**

REFINER PLATES

Parason designs & manufactures plates with different technologies, to have a wide range of selection for paper mills to suit their refining needs.

Engineered Trust

PRODUCT BASKET

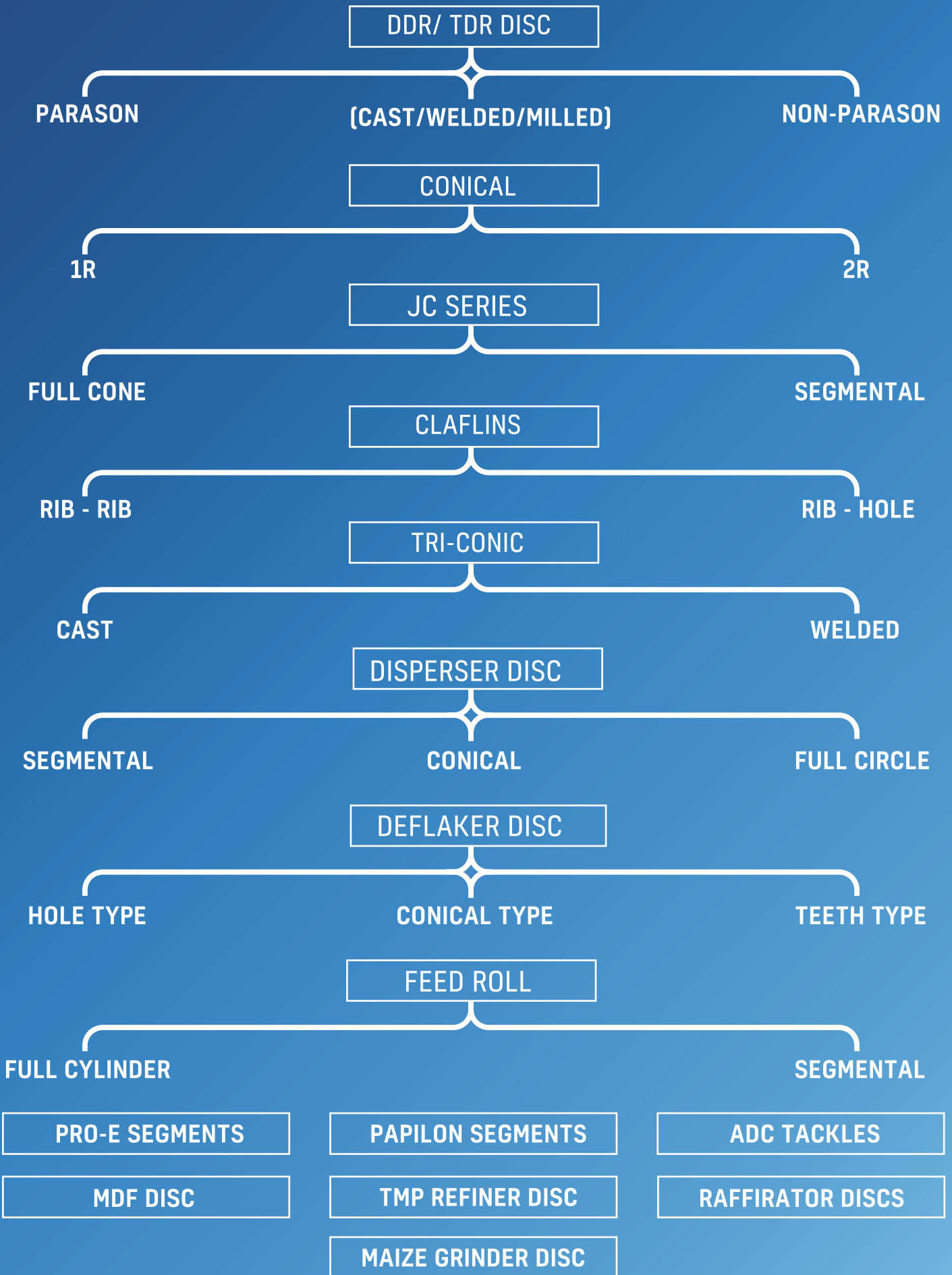

LEADERSHIP STATEMENT



Dr. C. P. Desarda

A Mastermind and leader in Engineering

Dr. Desarda an industrialist of par excellence under whose aegis the Desarda Group grew from strength to strength. Doctorate in Metallurgical Engineering with specialization in Chrome steel alloys from Brno University Cz Republic. He has been the driving force and powerful source of inspiration which has been helping Desarda Group to touch new heights. He was a leader of the masses, someone who would often champion the cause of the poor and downtrodden. He was a humanitarian at heart and an avant-grade visionary.



Shekhar C. Desarda

CEO

Mr. Shekhar Desarda has many facets to his personality. He is the Chairman cum Managing Director of Desarda Group, Executive Member of Indian Pulp and Paper Technical Institute (IPPTA) Saharanpur, India with many technical papers to his credit.

Mr. Shekhar Desarda is the man behind the transformation of a moderately performing company into a world class organization. After consolidating its position as a leading player in the pulp and paper industry sectors domestically, PARASON, flag ship company of the group has its presence in 60 countries across the globe as valuable supplier of Machinery and spares for Stock Preparation of Pulp and Paper Industry. His ideology is to become a globally admired organization that enhances the quality of life of all stakeholders through sustainable industrial and business development.

PARASON VGD SAS DISCS & TACKLES



1483 REGULAR
[12 SECTORS]

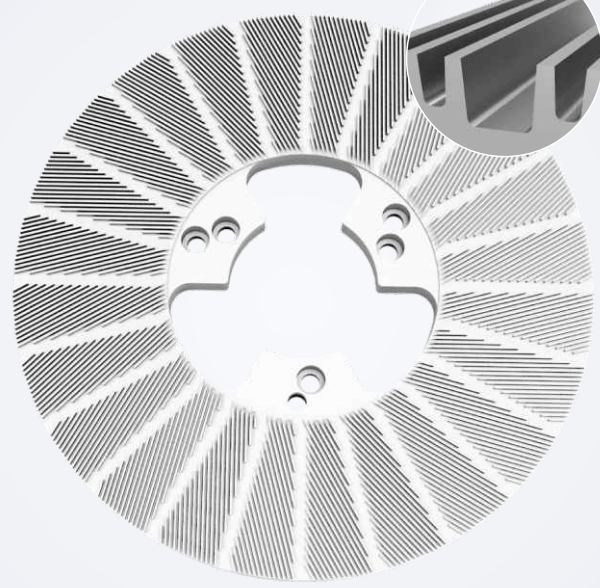

1483 VGD SAS
[24 SECTORS]

VGD:- Variable Groove Design
SAS:- Small Angle Sector

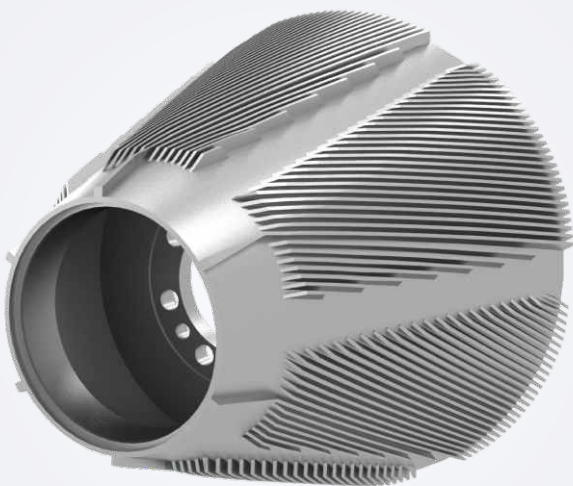

2734 SC REGULAR
[7 SECTORS]



2734 SF SAS VGD
[9 SECTORS]

REFINING AUDIT FOCUS WOULD BE ON

- Existing refining system study and its audit in detail
- Evaluate best suitable design and suitable alloy as per application
- On site field service
- User department and maintenance personnel's training and awareness
- Class room training focusing on technical, operational, maintenance, trouble shooting and latest advances in refining technologies made available at ease
- Organize one-to-one meeting of experts on refining to discuss and arrest problems with clear understanding and action plan
- Conduct survey on health of refiners and suggest with some replacement part change over from time to time to increase the efficiency and durability

Our Refining solutions will go a long way in improvement of mill's competitiveness. Our solutions with commercial concept demonstration and customers support, confidence, and participation helps in saving long term operational costs at a mill.

Technical Service Support

As believed and understood by every paper maker that refining is the heart for good paper making, PARASON's focus is always on optimization of available refining resources. We seek, collect and process data and bar design implications resulting in implementation of long term improvements in the refining area.

OPTIMIZED SOLUTION...Through Refining Audit

Reduce Refining Energy Consumption with Low Effort Solutions

Improving refining energy efficiency should be a priority in every mill. It's a win from every angle. With energy efficiency comes lower energy consumption, lower operating cost, and increased operational flexibility.

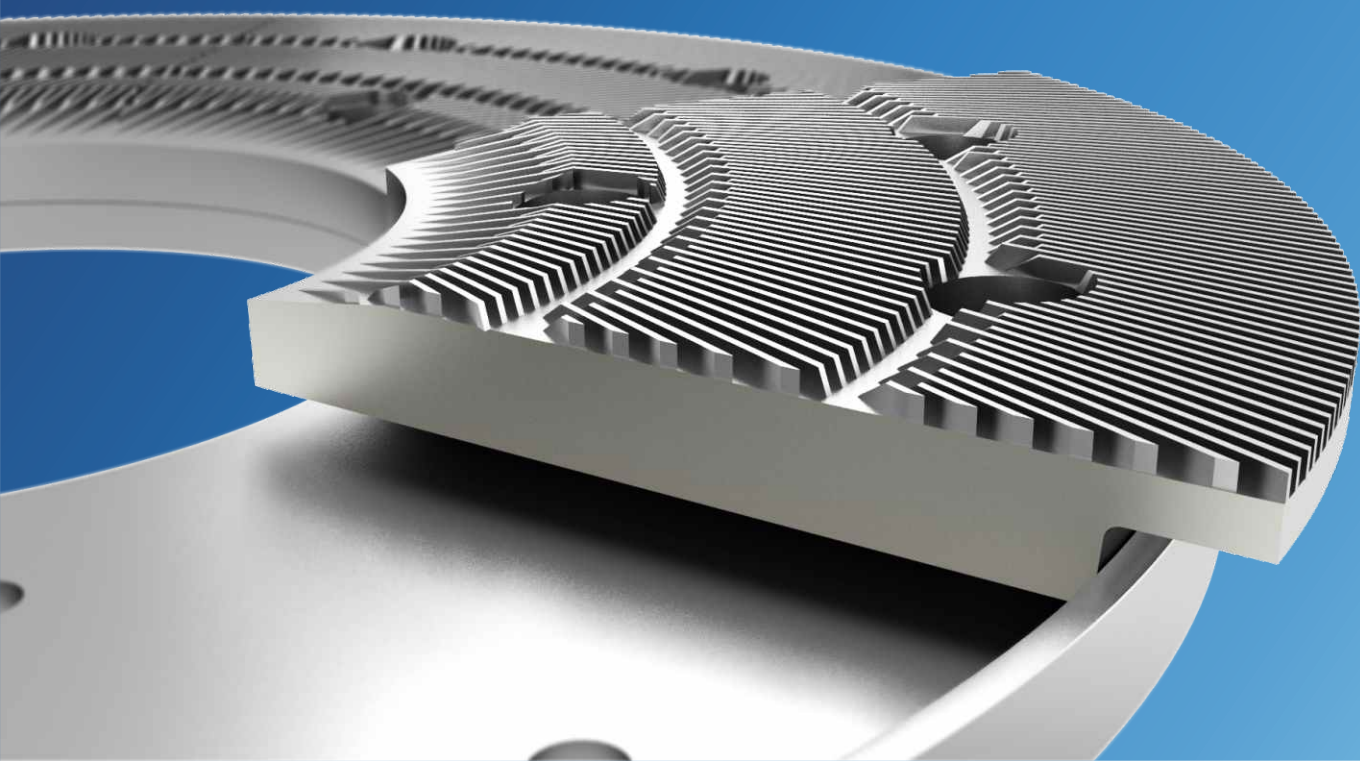

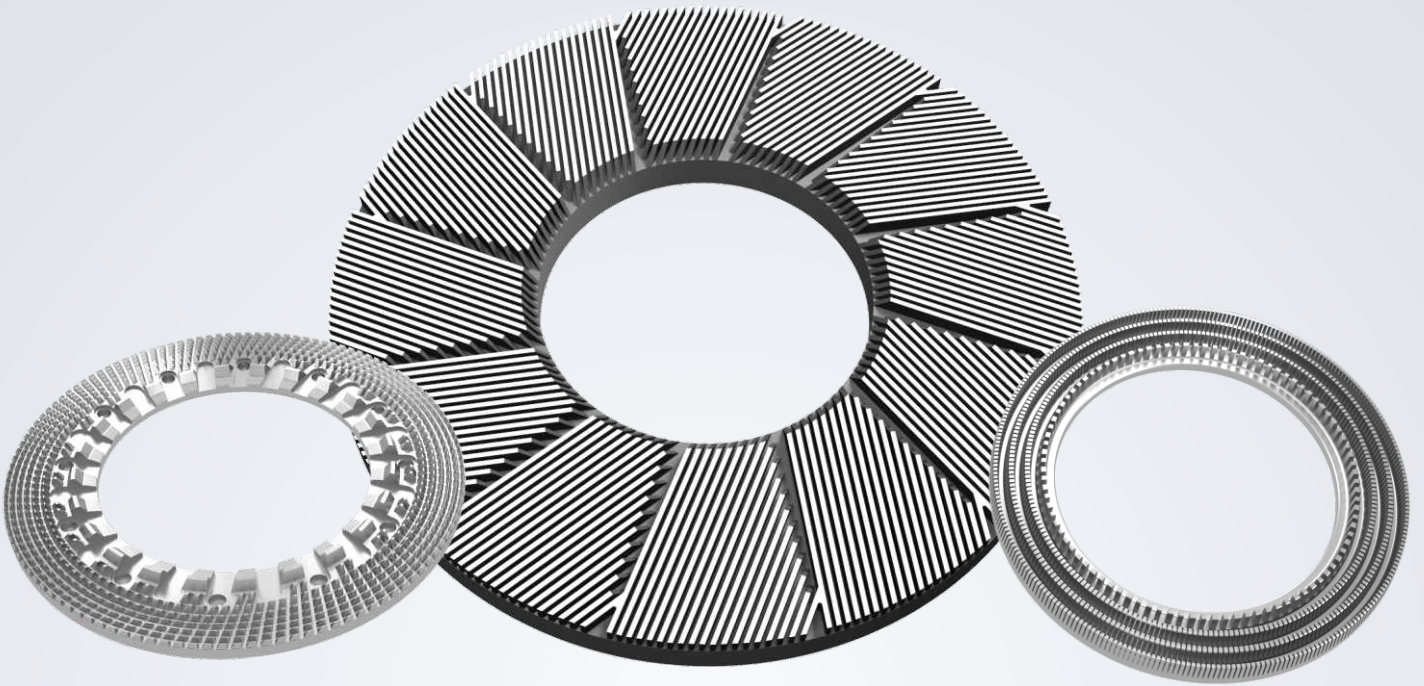

PARASON REFINER FILLING OFFERS

- Design to suit pulp & paper industry needs (pulping/refining)
- Available from 12" to 64" size and 25 HP to 8000 HP power loading
- Ensures right alloy (stainless steel alloys)
- Excellently casted, machined and finished disc
- Power saving from 6kw - 22 kw/hrs
- Enhanced plate life
- Uniform process results
- Precision CNC enabled disc profile with sophisticated software

SCHEMATIC DRAWING OF BAR WEAR

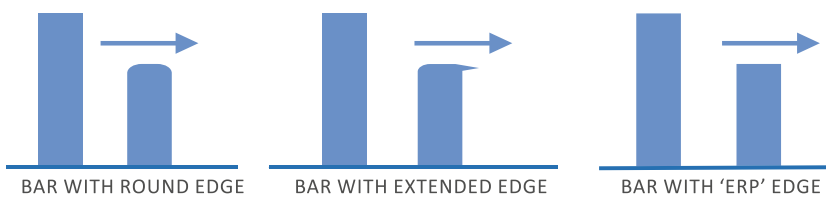

It makes a lot of sense that a refiner disc should have uniform wear properties. Normally, the variation in the wear of the refiner plates may be wavy, serrated, or flat type.

The wavy & serrated wear causes maximum fibre damage and multiple disadvantages of high power consumption, increased cost per tonne, load variations, etc. PARASON has innovated the concept of 'ERP' that is Edge Retention Property during strenuous refining conditions, 'ERP' plate has flat wear.

Casting is done by using the latest technology to provide the best condition for the alloys in temperature, time, melting technique to determine the best suitable alloy. A due consideration to properties of erosion, corrosion, wear resistance of refiner plates is taken care of.

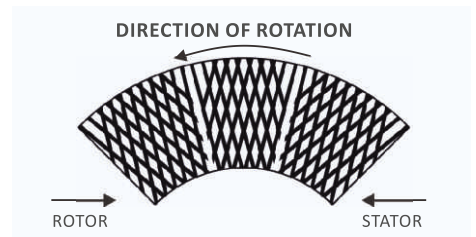

SCISSOR ACTION

Refining plates work on the principle of scissors. The multiple resolution and number of bar crossings creates millions of scissors edges. Refining takes place at the bar edges, hence it is essential to have right angle bar edge during refining.

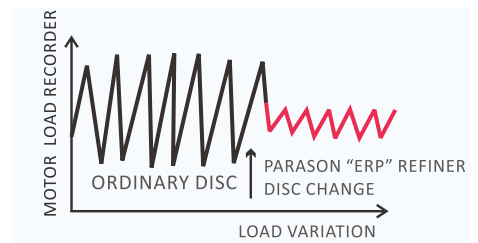

IMPROVED ENERGY EFFICIENCY

PARASON DISC with 'ERP' has shown improvement in the energy consumption with power saving from 6 KW/hr to 22 KW/hr in various applications grossly. The power saved annually adds to profitability of the mills.

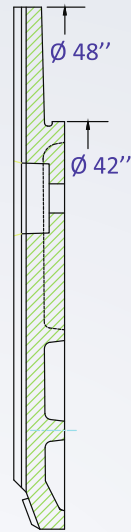
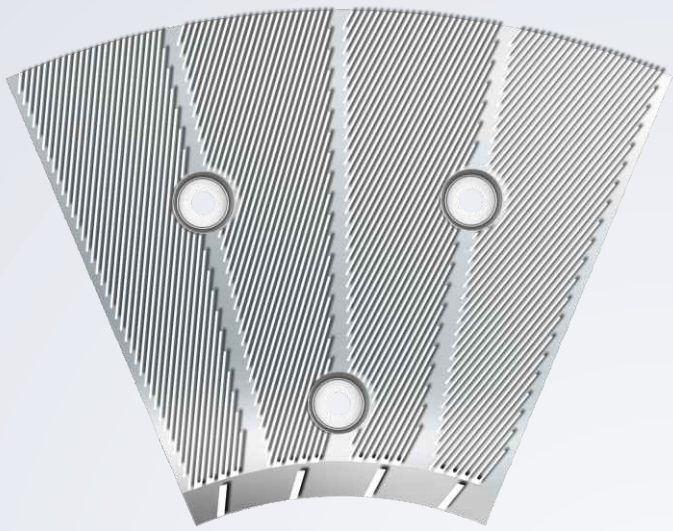

Overhung plate designs with higher outer diameter, increases the capacity of the refiner & cutting edge length of plate. Resulting increased plate life and improved in pulp quality with enhanced capacity.

PARASON SEGMENTAL REFINER DISC 34", 40", 42", & 48" DDR

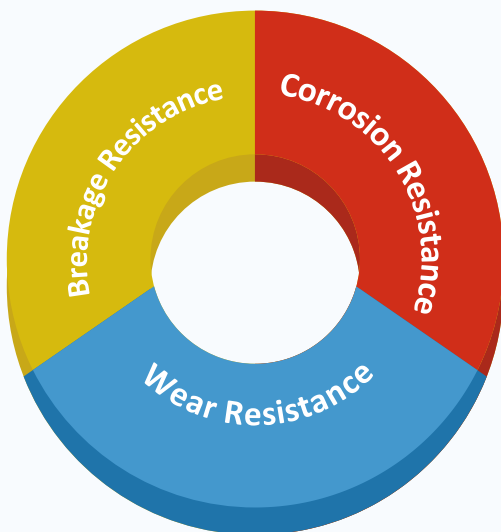

Metallurgy of Refiner Disc

- There are three basic metallurgical properties required in any refiner discs
 - Corrosion resistance
 - Wear resistance
 - Breakage resistance
- There must be correct balance of these three properties
- It is necessary to improve the toughness without sacrificing the wear resistance which is a great challenge
- Parason have developed wide range of metallurgy to suit refining of various applications

New proposed bar designs go through intensive R & D focused on field requirements like throughput, plate life, & energy savings with commitment to customer satisfaction.

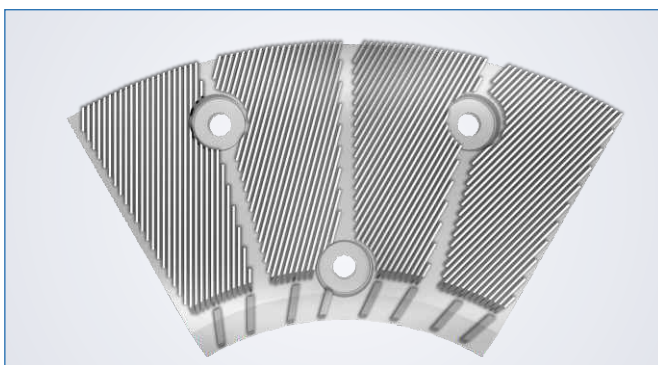

40" DDR DISC

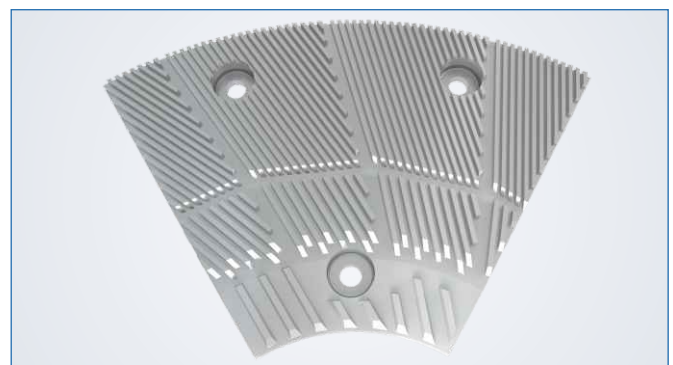

34" DDR DISC

WELDED PLATE MANUFACTURING METHODS

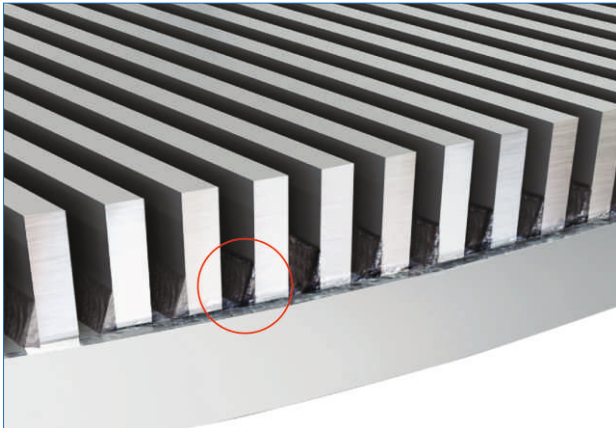

Conventional TIG Welding Process

Feature short fall

- M.S. base is used
- Welding in grooves
- Less throughput
- Visible joints
- Less mechanical strength
- Higher energy consumption
- Less life

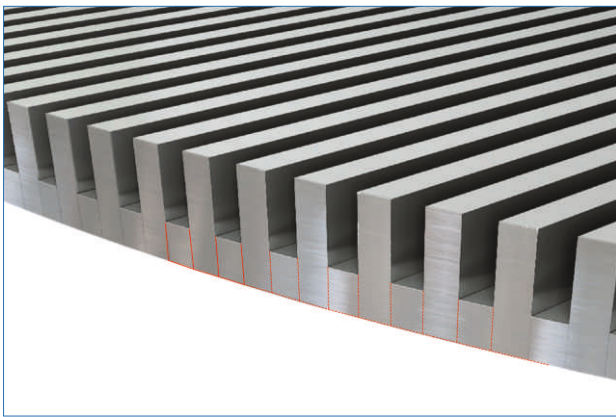

Diffusion Bonding Process

Feature short fall

- Weaker mechanical strength
- Visible welding from top and bottom
- Fibre hang-ups
- Can damage refiner in case of accidents
- Design limitations

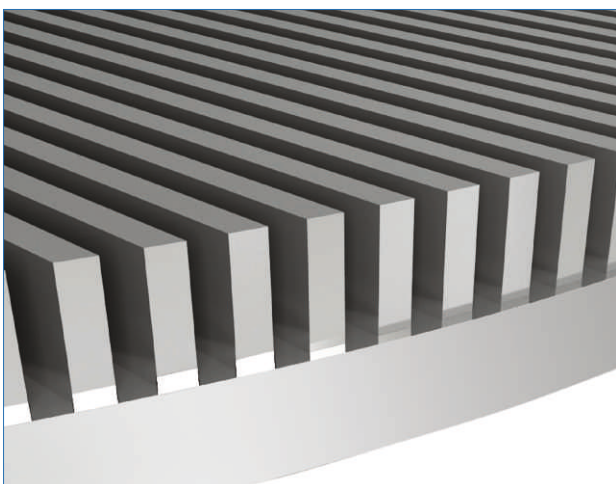

Parason refining solutions provide uniform & efficient fibre development with ultra low intensity refiner plates.

Parason Laser Technology

Features

- Strongest mechanical strength
- Application based MOC
- Zero draft angle of the bar
- Narrow bar width 0.8, 1.2, 1.6, 2.0, 2.5, 2.8, 4, 5 mm
- Full SS-304 base, with or without dams
- Invisible joints
- Clean grooves, smooth surface
- Higher throughput
- Uniform pressure
- No fibre hang-up
- Low power consumption

WELDED PLATE MANUFACTURING METHODS

PARASON AWT for Leading Edge of Ribs

"Refining is done at Leading Edges"

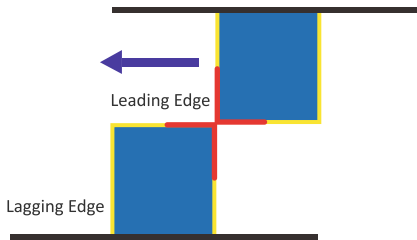

Now Parason has developed AWT treatment for Leading Edge Retention Property to Ribs for Welded Refiner Plates.

PARASON AWT (Anti Wear Treatment)

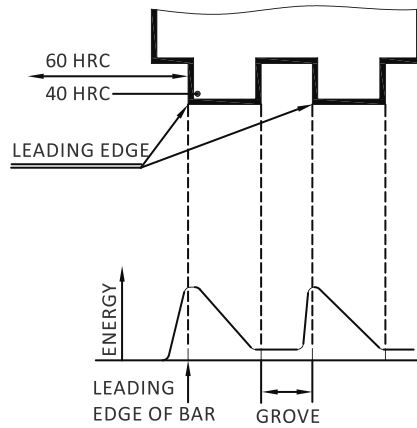

Microscopic View (AWT)

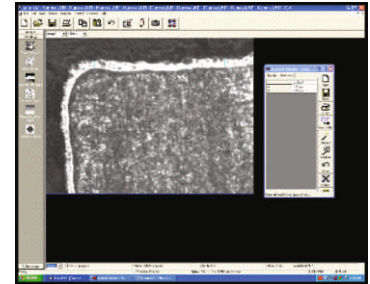

In this Leica image analyzer all qualitative metallurgical parameters are converted into quantitative metallurgy

PARASON AWT (Anti Wear Treatment)

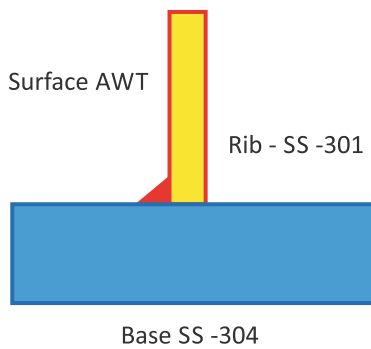

Field result of International Paper (APPM), India
Raw Material: Hard Wood Pulp (Dec-2014)

SN	Condition	Life (Days)	% Increase
1	Welded	50	100
2	Welded+AWT	83	166

PARASON... A STEP AHEAD IN CAST & MILLED FILLINGS

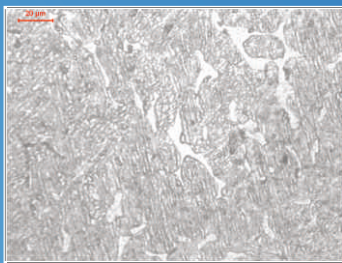

Before CTT

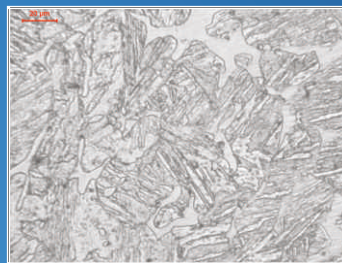

After CTT

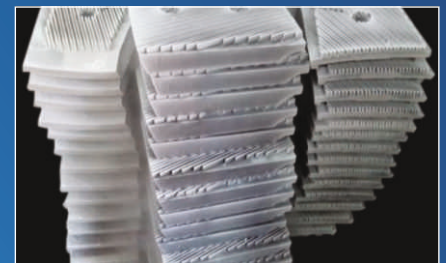

PARASON CTT (Complete Transformation Treatment)

The wear resistance is improved by the special treatment to transform all meta stable microscopic phases into the stable microscopic phases.

The wear resistance of the disc is improved without sacrificing the breakage resistance this treatment is applicable for the Cast as well as Milled refiner plates & tackles of special metallurgy.

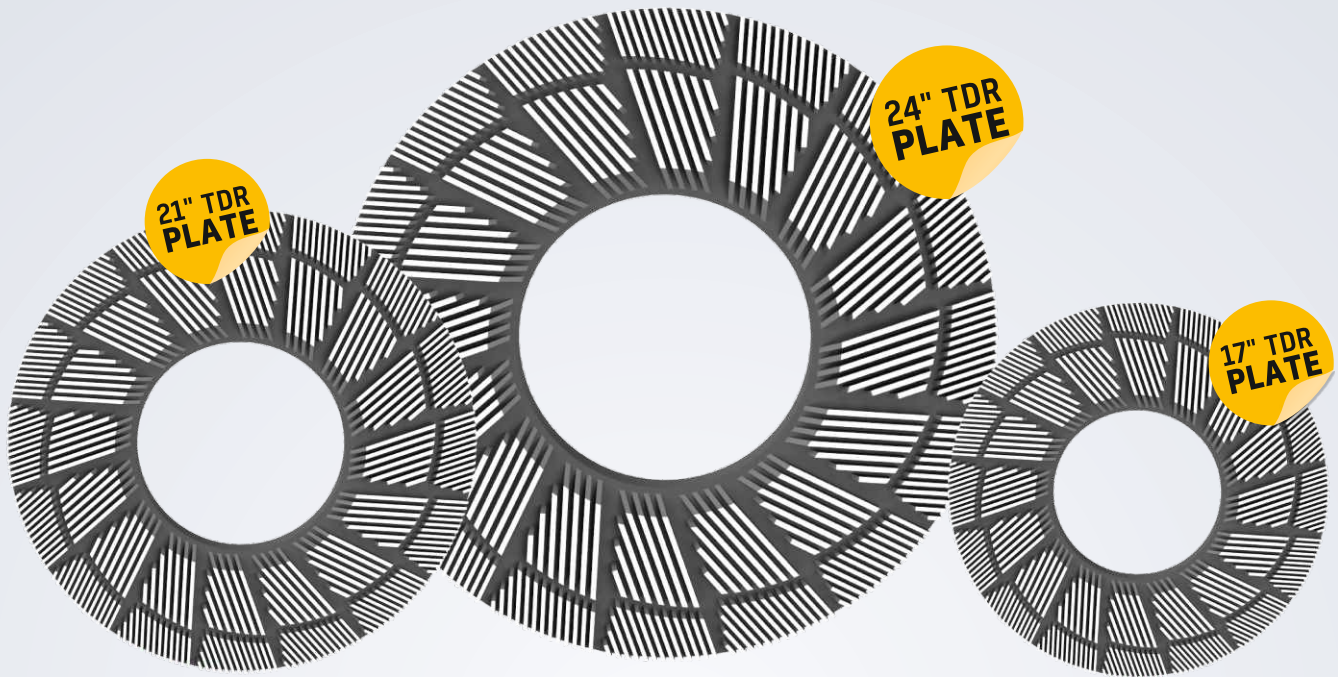

PARASON VARIABLE RIB DESIGN PLATES (VRD)

PARASON Variable Rib Design refiner plates are manufactured using Special Casting & CNC technology to provide the maximum uniformity in the refining zone.

PARASON Variable Rib Design refiner plates are manufactured with special cast technology to provide uniform hardness throughout, the plates wear uniformly.

- Suitable for mixed furnish refining
- Normally long fibres & short fibres need to refine separately with different bar patterns as per required SEL & CEL
- The VRD design is made to deal with mixed furnish
- The peripheral velocity for long fibre zone is little lower than HW zone which is need for respective furnish
- The retention time for long fibre is higher than short fibre
- The rib height for long fibre zone is higher & smaller for short fibre zone to give desired refining effect
- This design ensures the minimum shortening or damage to the fibre which gives better strength to the paper with higher breaking length
- There is base taper in the disc for better throughput & optimization of hydraulic capacity of disc
- SAS design offers close control over cutting angle of refiner disc

Special Features:

- Inlet coarse bar pattern
- Outlet fine bar pattern
- Base taper
- No breaker bar
- SAS design
- No dam
- Inclined parting line between 2 zones

Advantages:

- High fibrillation
- Power saving /T/o SR
- High throughput
- No collar formation
- Less fibre cutting
- No plate clashing

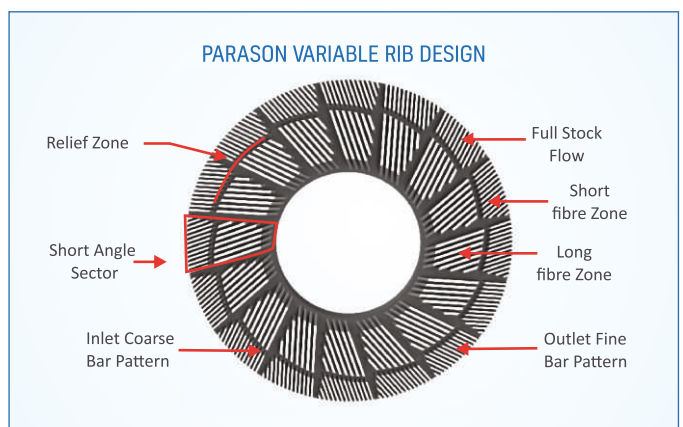

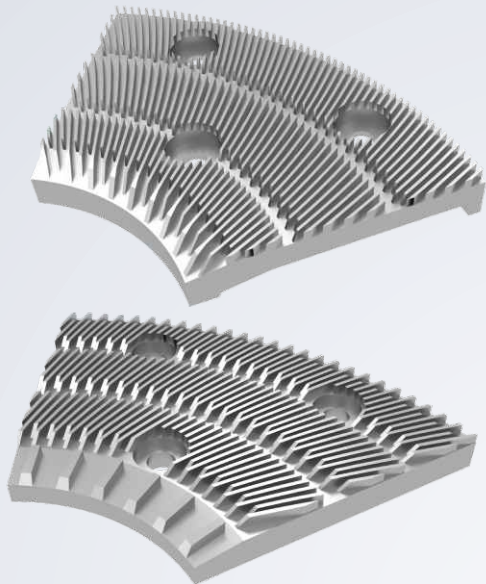

CURVED BAR DESIGN

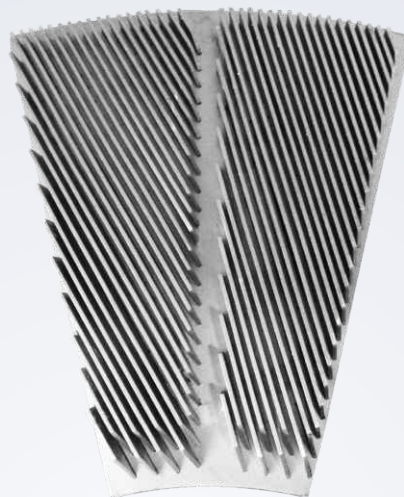

SEGMENTAL DESIGN



FULL CIRCLE DESIGN / Under Hung

PARASON FINEDGE WELDED BAR REFINER PLATES

PARASON Finedge Welded Bar refiner plates are manufactured using Special Casting & Robot Welding CNC technology to provide the maximum uniformity in the refining zone. PARASON Finedge Welded Refiner Plates are welded with special welding technology. The plates will wear uniformly over time with zero draft angle on the bar. With higher bar height and minimum bar width, the hydraulic uniformity is maintained for longer time.

PARASON precision special cast, laser & welding manufacturing process minimizes groove width variations, which allows finer bar to optimize low intensity applications. Plate life is maximized due to high bar height that is able to maintain with this technology.



Laser Machining Center

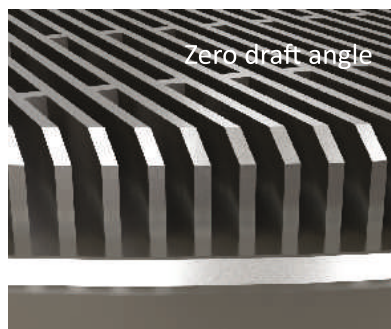

More bar height

PARASON Offers

Parason manufactures the Welded Refiner Plates, Tackles & Tri-Cones with adequate height of the rib to offer more disc life & throughput

Special metallurgy

SS-304 base
SS-301 ribs
SS-17-4 precipitated hardened ribs
Specialised AWT treatment

Special Features:

- Narrow bar width from 0.8, 1.2, 1.6, 2.0, 2.5, 2.8, 4, 5 mm
- High Cutting Edge Length (CEL)
- Zero draft angle on the bar
- More bar height - more life
- Special metallurgy

Benefits:

- Low Specific Edge Load (SEL)
- Good fibrillation - consistent fibre treatment
- Higher throughput
- Suitable for hardwood, softwood & recycled fibre
- Low power consumption

User's Requirements:

- Strength development of fibre
- Optimization of product properties
- Reduction in raw material cost
- Reduction in energy consumption

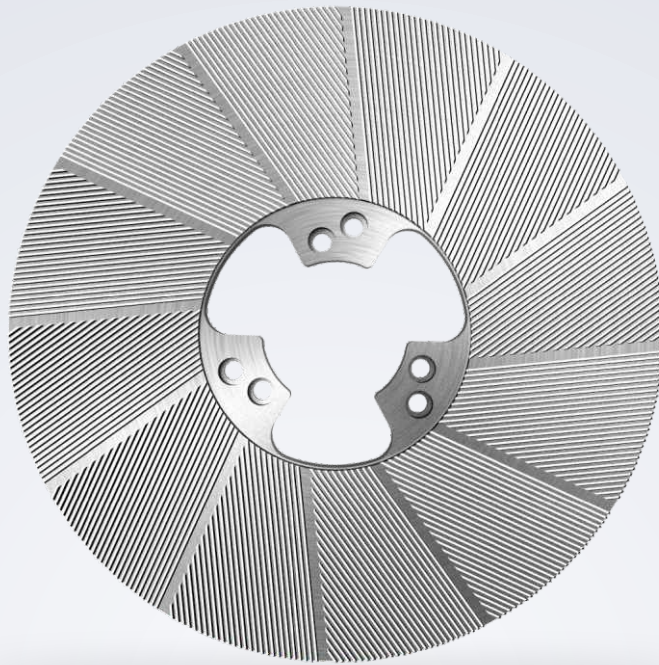

PARASON FINEDGE MILLED - REFINER PLATES

Application & Salient Features

PARASON Finedge Milled Bar Refiner Plates are manufactured using CNC technology to provide the maximum uniformity in the refining zone.

PARASON milled bars are cast in own foundry as a solid piece to provide uniform hardness throughout. The plates will wear uniformly over a time. The zero draft angle on the bars help in maintaining longer hydraulics.

The PARASON precision CNC Milling manufacturing process provides accurate groove width, which allows finer bar to optimize low intensity applications. Plate life is also maximized by re-milling which allows 2-3 life cycles.

4 Axis CNC machining center for manufacturing fillings of various applications.



Special Features:

- Narrow bar width
- Bar width range up-wards 1.6mm, 2.0mm, 2.25mm, 2.5mm
- High Cutting Edge Length (CEL)
- Zero draft angle on the bar
- Long life (Re-milling possible)
- Special metallurgy (17-4 PH)

Benefits:

- Low Specific Edge Load (SEL)
- Good fibrillation - consistent fibre treatment
- Constant throughput
- Suitable for Hardwood, TMP, Non-wood fibres (Cotton) & Recycled fibre

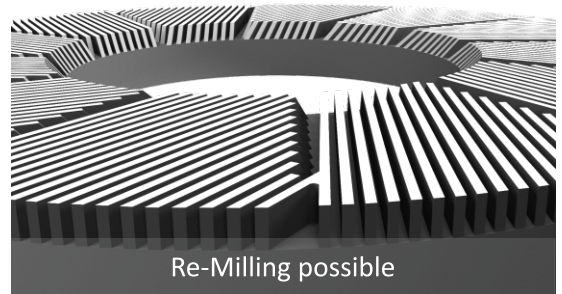

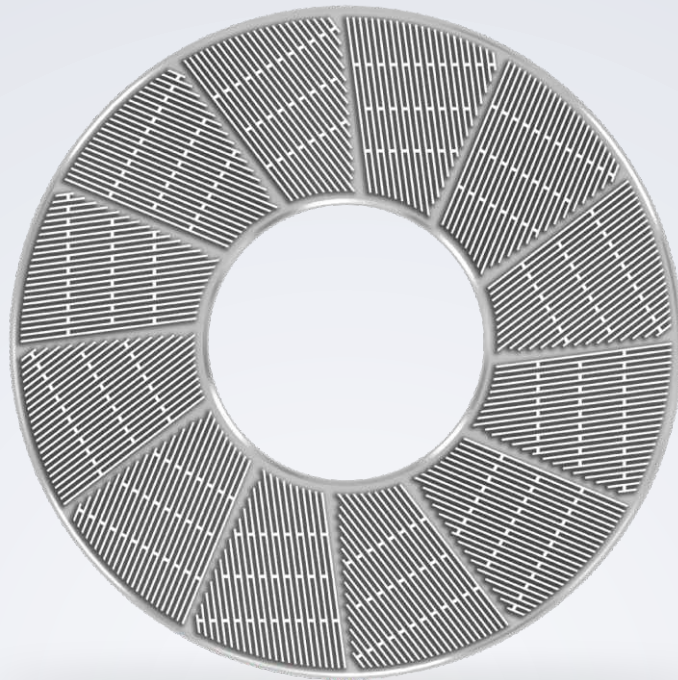

PARASON FINEDGE WELDED - REFINER PLATES

Application & Salient Features

PARASON Finedge Welded Bar refiner plates are manufactured using Special CNC technology with Robotic Welding to provide the maximum uniformity in the refining zone. PARASON Finedge Welded Refiner Plates are cast in special metallurgy suitable for special welding technology with higher bar height and lower bar width.

PARASON precision Special Cast, Laser & Welding, manufacturing process minimizes groove width variations, which allows finer bar to optimize low intensity applications. Plate life is maximized due to higher bar height.

Utilizes the AX-C robot controller for fast communication and improved robot movement control



Special Features:

- Narrow bar width range 1.2mm, 1.6mm, 2.0mm, 2.5mm, 2.8mm
- High Cutting Edge Length (CEL)
- Zero draft angle on the bar
- More bar height - More life
- Special metallurgy

Benefits:

- Low Specific Edge Load (SEL)
- Good fibrillation - consistent fibre treatment
- Constant throughput
- Suitable for hardwood & recycled fibre

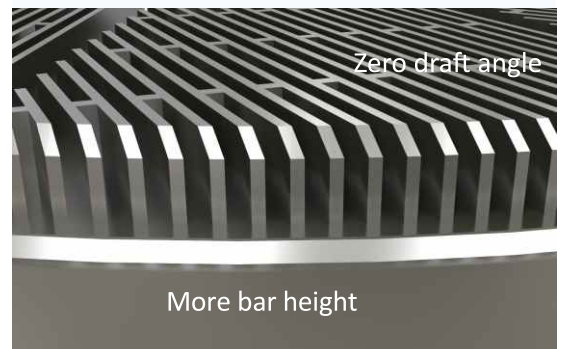

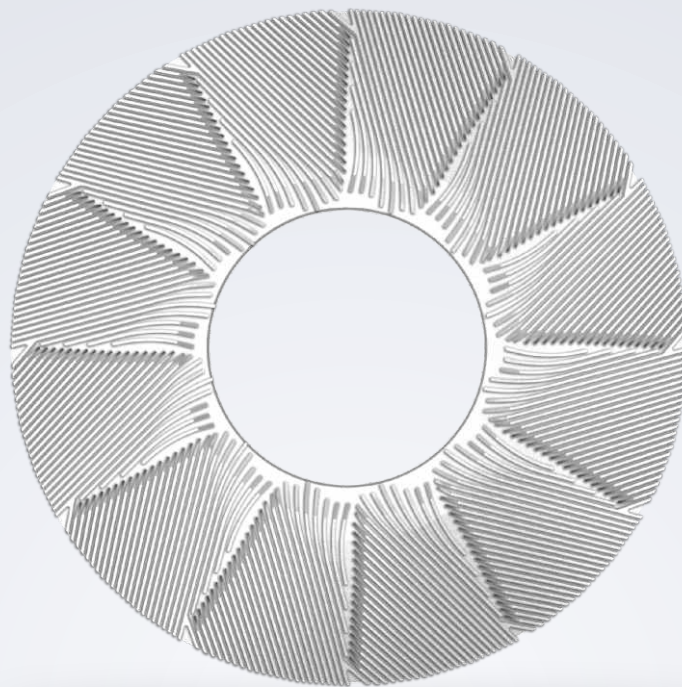

PARASON FINEDGE INLET CURVED BAR - REFINER PLATES

Application & Salient Features

PARASON Finedge Inlet Curved Bar Refiner Plates are manufactured using special casting & CNC technology to provide maximum uniformity in the refining zone.

PARASON Finedge Curved Bar refiner plates are specially cast in own foundry to provide uniform hardness throughout. The plates will wear uniformly over a time having a longer bar length. The flow of pulp follows the grooves between the bars and results in longer residence time. The result of Finedge Curved bars helps in more gentle refining action which continues over a longer time. Curving the refiner bars at inlet enables them to function better as a pump. The half dams between sectors, further improve the pulp residence time resulting into improved refining.

The PARASON precision Special Casting & CNC manufacturing process provides accurate groove width, which allows finer bar to optimize low intensity applications.

Half dam in the valley between sector

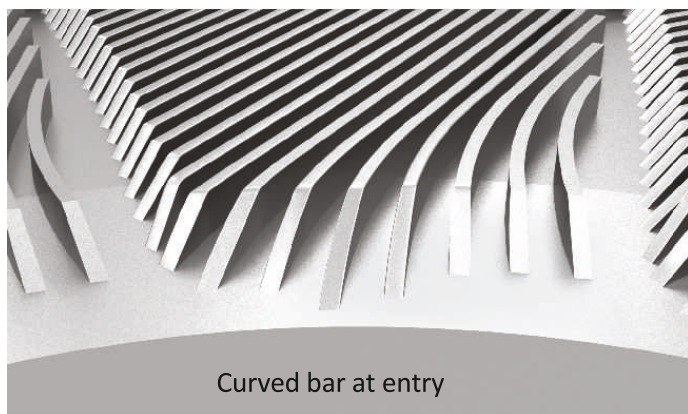

Special Features:

- Longer pulp residence time
- High Cutting Edge Length (CEL)
- Finedge curved bars function better as a pump
- Suitable for hardwood & recycled fibre
- Special metallurgy

Benefits:

- Finedge Curved bars - more gentle refining action
- Low Specific Edge Load (SEL)
- Good fibrillation - consistent fibre treatment
- More throughput
- Suitable for Hardwood & recycled fibre

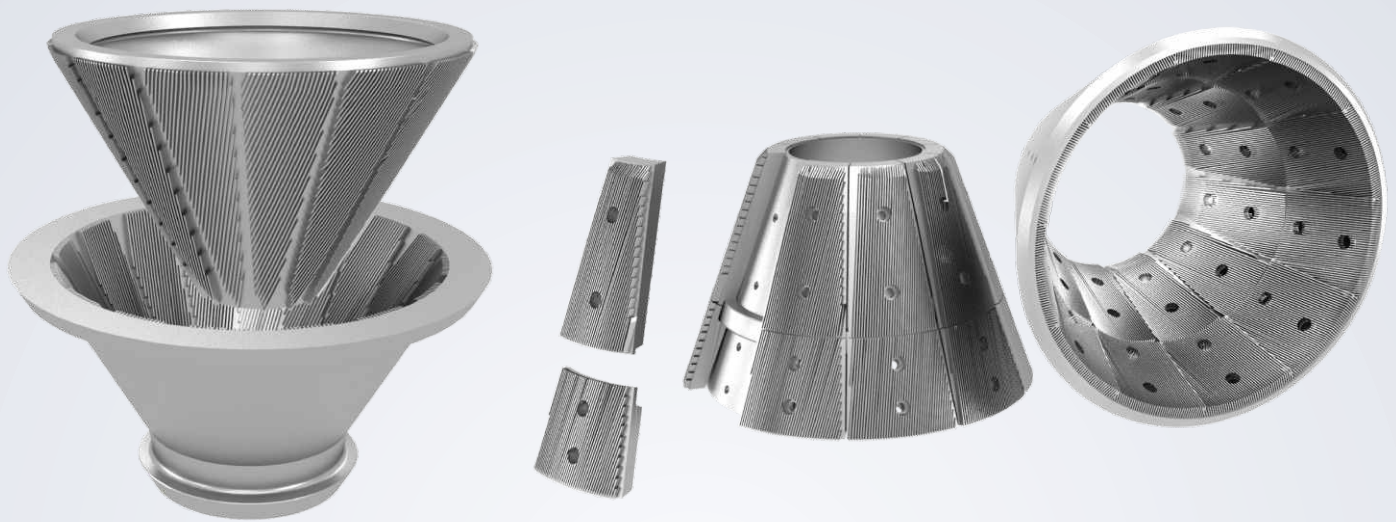

PARASON CONICAL REFINER FILLINGS

Shallow Angle Cone-Flow Fillings (JC-0 Series)

PARASON conical refiner fillings offer exceptional high performance level of fibre processing.

PARASON manufactures Conical Refiner Fillings of various designs, sizes to suit the industry needs. PARASON Conical Fillings offer flexibility of various designs to optimize the process. Made of high strength, toughness, and corrosion resistant stainless steel alloy.

Uniform wear ensures longer life. Precision engineering to ensure consistent quality and superior performance. PARASON'S innovation of ERP™ that is Edge Retention Property makes the application unique and offers energy saver design.

TYPE	RIB WIDTH	GROOVE WIDTH	P-PARASON
Microbar	1.2	1.9	MB - Extra Low Intensity Refining
Welded	1.6	1.6	SW - Low Intensity Refining
PSF	2.0	3.0	SF -Short fibre Fine
PSM	2.5	3.5	SM - Short fibre Medium
PSC	3.0	4.0	SC - Short fibre Coarse
PLF	4.0	5.0	SF -Short fibre Fine
PLM	4.5	6.0	SM - Short fibre Medium
PLC	5.5	7.0	SC - Short fibre Coarse
PFS	4.0	3.0	FS - Fibrillating Short
PFL	8.0	5.0	FL - Fibrillating Long
PTM	3.0	7.0	TM - Trimming Medium
PTC	4.5	8.5	TC - Trimming Coarse
PMX	4.5	3.6	MX - Mixed fibre

PARASON offers cast CONICAL fillings for all models of JC-0 refiners. Large number of patterns with thick to thin bars suitable for different refining applications.

The fillings are with PARASON'S innovation of ERP™ property which ensures efficient refining life with lower energy consumption. PARASON can fulfill the demand of the industry irrespective of size and model with custom designs.

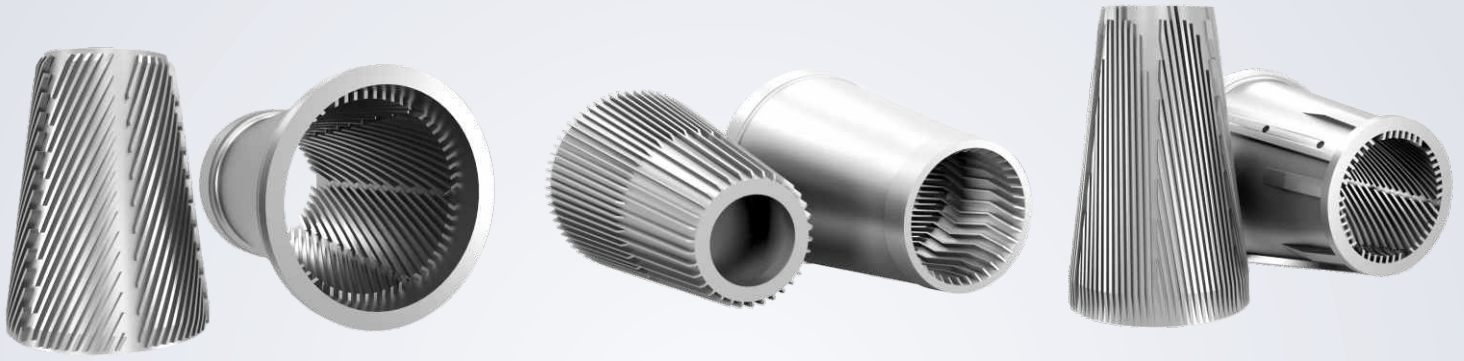

LOW ANGLE MONOBLOCK FILLINGS

PARASON cast and duly machined fillings are available for all models of conical refiners suitable for Jordan 1R, 2R, 3R, Jones, Fibre master, etc.

These single piece cast fillings with precision grinding of sharp edges ensures minimum wear to optimize life and performance. Fillings are built with special treatment for long lasting services.



COTTON FIBRE FILLINGS

HIGH ANGLE MONOBLOCK FILLINGS

PARASON manufactures Claflin fillings for every model like 101, 202, 303, F9 refiners. The fillings are cast stainless steel offering superior performance in the development of fibre. Long life of the fillings ensure better economy.

Benefits:

- Uniform fibre treatment
- Long periods of economical refinings
- Units of maximum structural strength for desired stock treatment
- Fast, dependable deliveries
- High grade steels - heat treated with edge retention property 'ERP'

Metallurgical quality control is precisely maintained at every step from raw material, heat treating to final testing desired hardness and wear resistance that virtually eliminates edge rounding. Wear resistance and toughness results in long productive life.

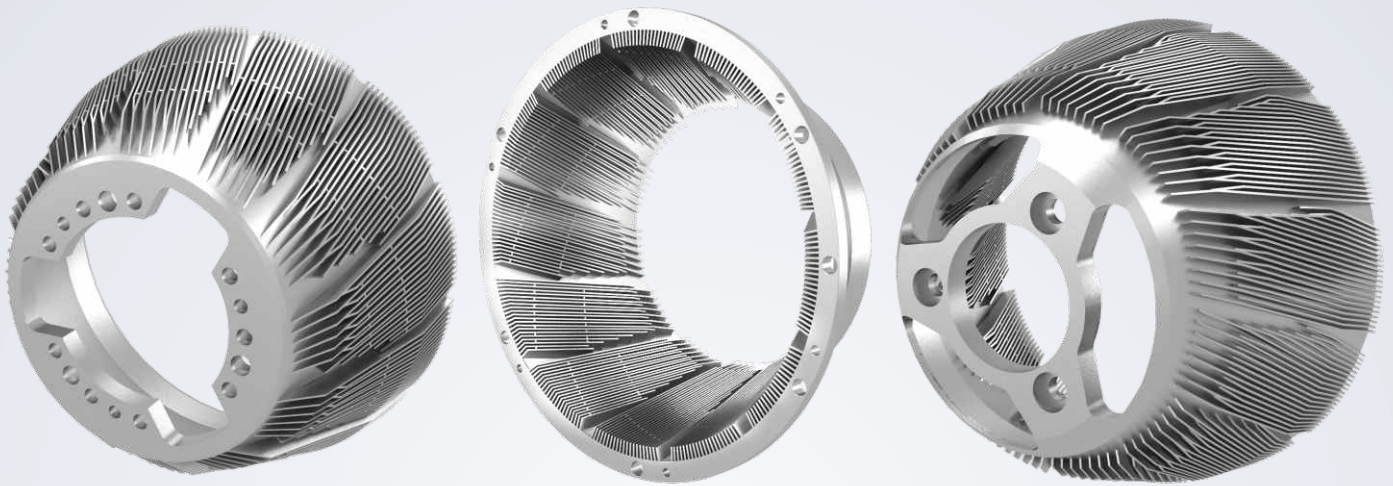

PARASON TRICONE FILLINGS

Shallow Angle Cone-Flow Fillings [Triconic Series]

PARASON cast and fabricated and duly machined fillings are available for almost all model of RTC 1000, RTC 2000, RTC 3000, RTC 4000 suitable for different grades of paper application. We supply fillings both in cast as well as fabricated type.



Conical Disperser Fillings

Various standard patterns for HW and SW refining, for broke refining and for refining of mechanical pulps, and various specific fibre types. Fine edge refiner plates suitable to the application for improved capacities in both short fibre and long fibre refining.

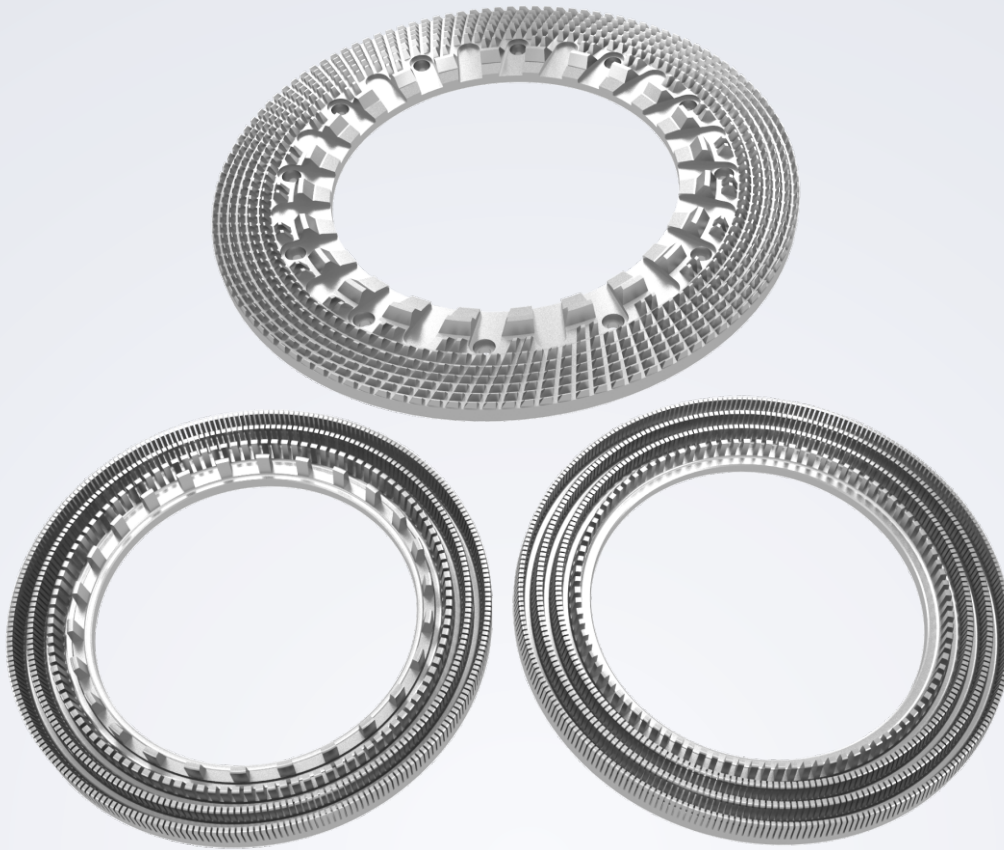

PARASON DISPERSER FILLINGS

PARASON DISPERSER DISC WITH QST (Quartz Surface Treatment)

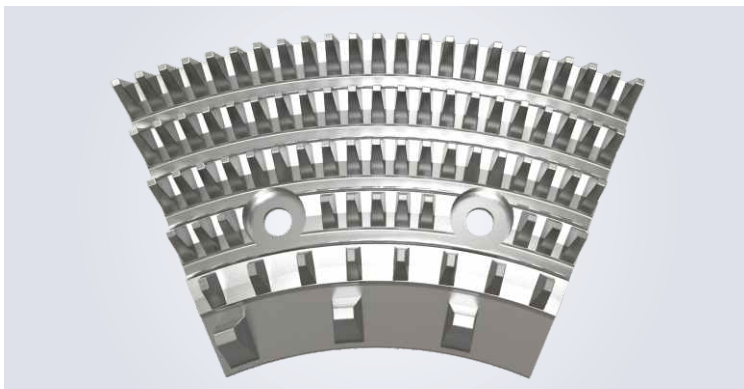
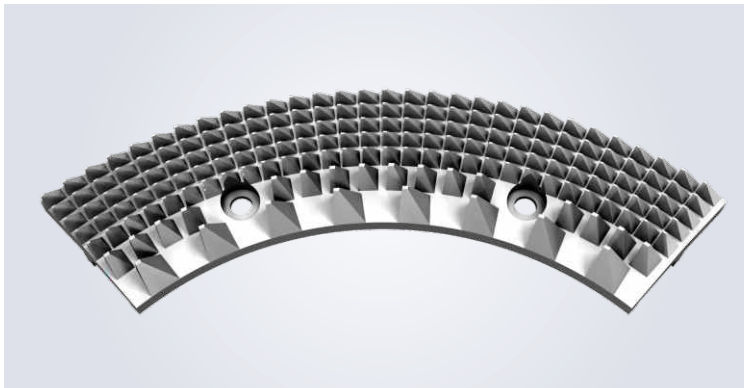

Parason manufactures the Disperser Discs in various designs and metallurgy

Disperser discs often face typical initial setting troubles like :-

- Excessive Vibration
- Higher Noise level
- Load hunting
- Disturbed performance

Parason have developed Quartz Surface Treatment (QST) to overcome above problems.

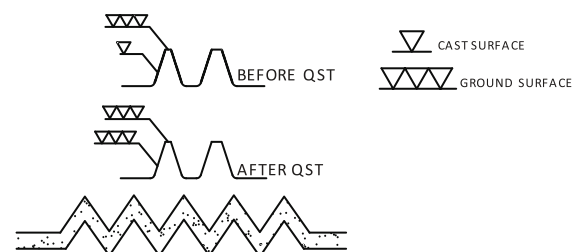

PARASON HC DEFIBRATOR FILLINGS

PARASON makes refiner plates to suit the fibre board industry such as

- Medium Density fibre board (MDF)
- Particle board, Hard board
- Insulation board, Siding

PARASON technological expertise pattern making of dams, Sub surface dam, Root taper, Bar design thickness by CNC machines ensures optimum performance. These filling are cast in Alloy Stainless Steel and heat treated, ground finished, dynamically balanced and made ready as per required application.

PARASON ensures optimum results by

- Selection of proper design
- Selection of right alloy
- Excellent casting & heat treatment
- Ground finished and dynamically balanced

Technical experts apply various criteria as selection such as

- Impact strength
- Wearing resistance
- Corrosion resistance
- Cavitation resistance
- Abrasion resistance

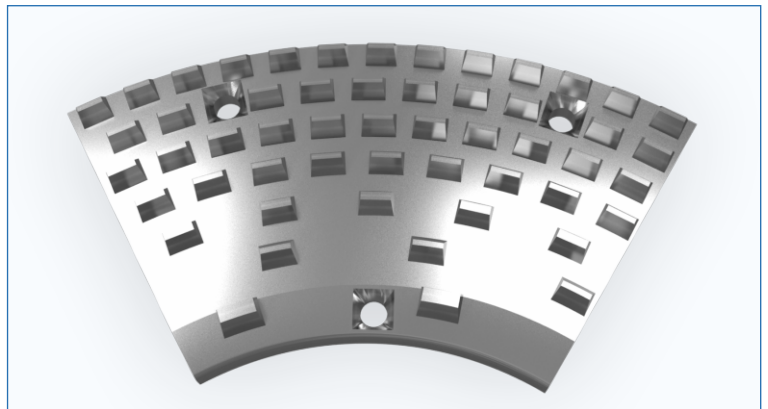

Maize Grinding Disc

Parason is also serving allied industries like Starch, Gum industries

Parason manufactures the Maize Grinding discs in various designs and metallurgy. Complete range of Maize Grinding disc from 26" - 52"

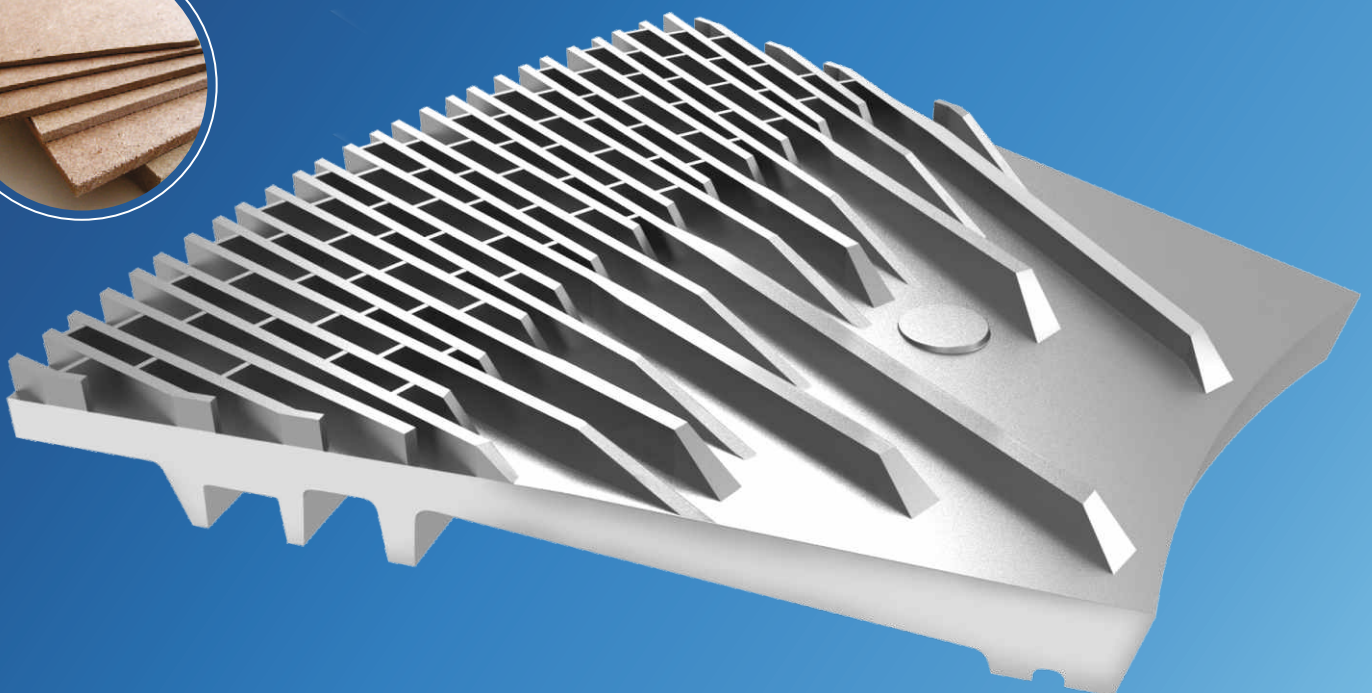
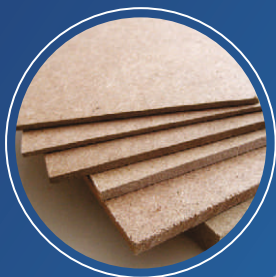



PARASON

Engineered Trust

Corporate office: Golden Dreams IT Park, 4th Floor,
E-27, Chikalthana MIDC, Beside Millennium Park,
Aurangabad (MH), India - - 431006

Tel. : +91 (0) 240 - 6644 444
Customer Service No: +91 96734 49922

Email: info@parason.com
Web: www.parason.com

FOLLOW US



Scan to watch videos

Note: Content subject to change without any prior notice | Power consumed may vary as per furnish combinations

"No part of this catalog may be reproduced or copied in any form or by any means (graphic, electronic or mechanical, including photocopying recording, taping, or information retrieval system) or reproduced on any disc, tape, perforated media or other information storage device, etc., without the written permission of the company, Breach of this condition is liable for legal action."