



PARASON

Complete Pulping Solutions

For consistent stock preparation



SHARPEDGE DRUM PULPER

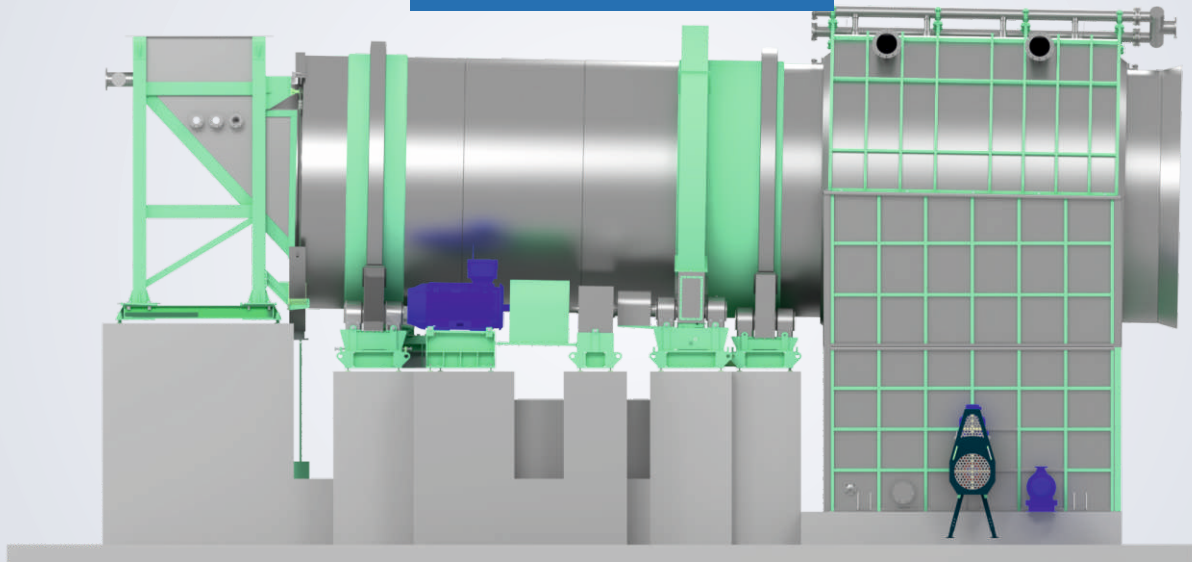

HI-CONSISTENCY PULPING LOOP

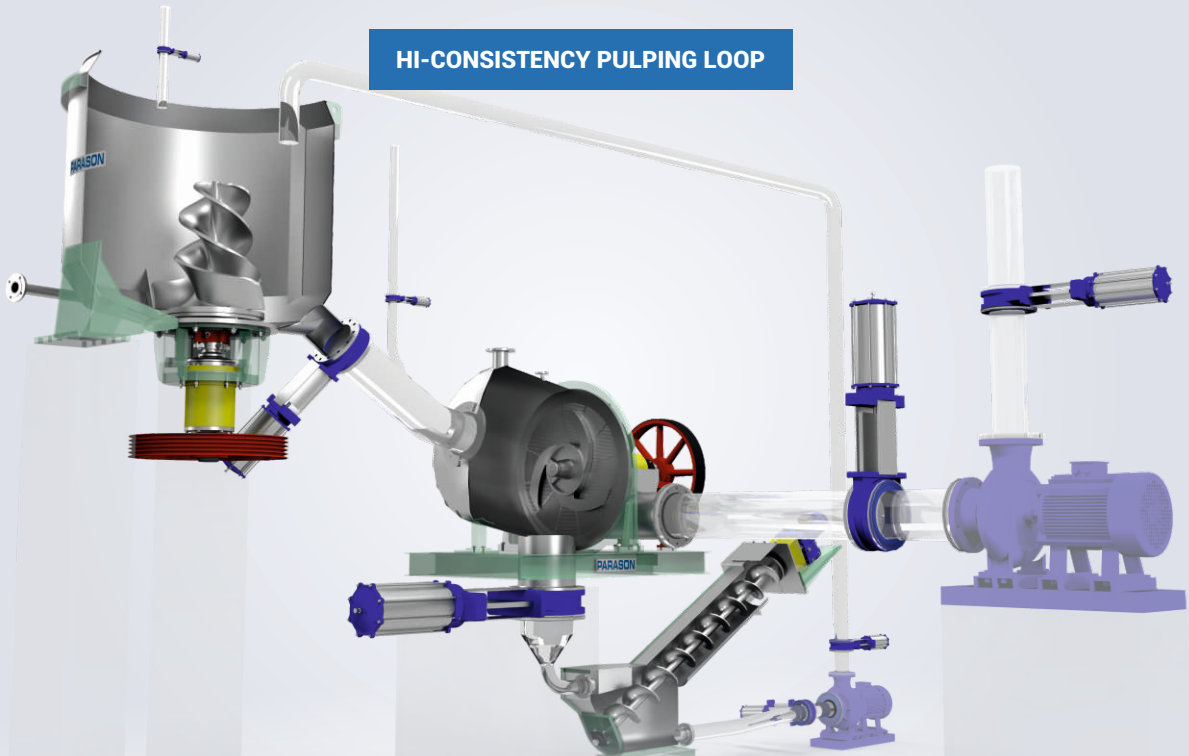

PARASON UNDER PULPER (UTM)

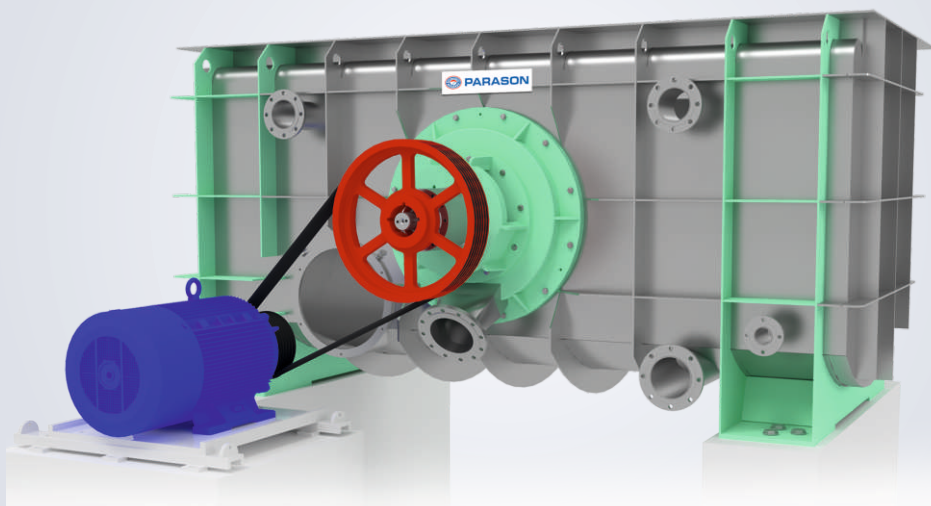

LOW-CONSISTENCY OFFSET PULPING LOOP

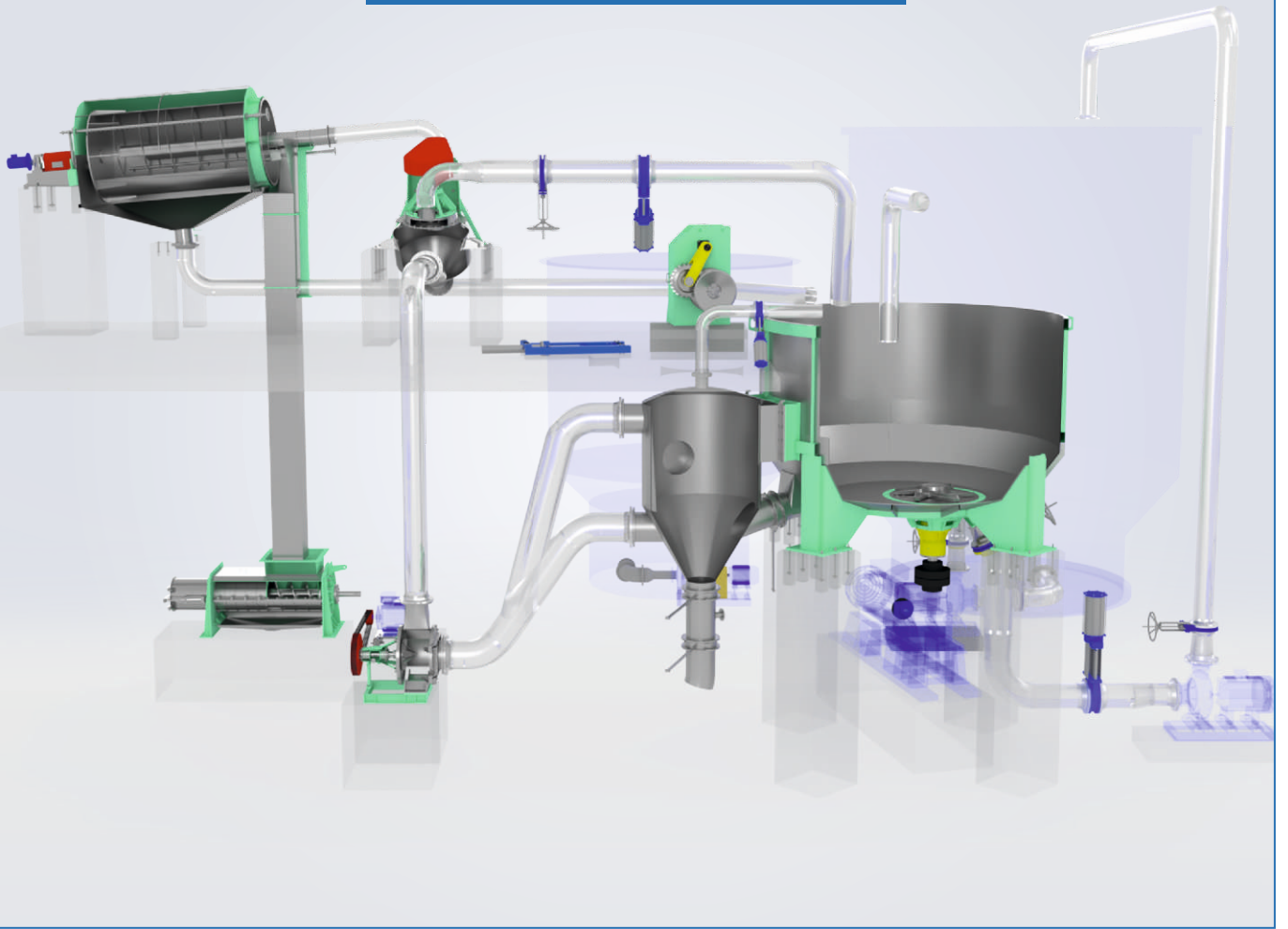

LOW-CONSISTENCY PULPING LOOP

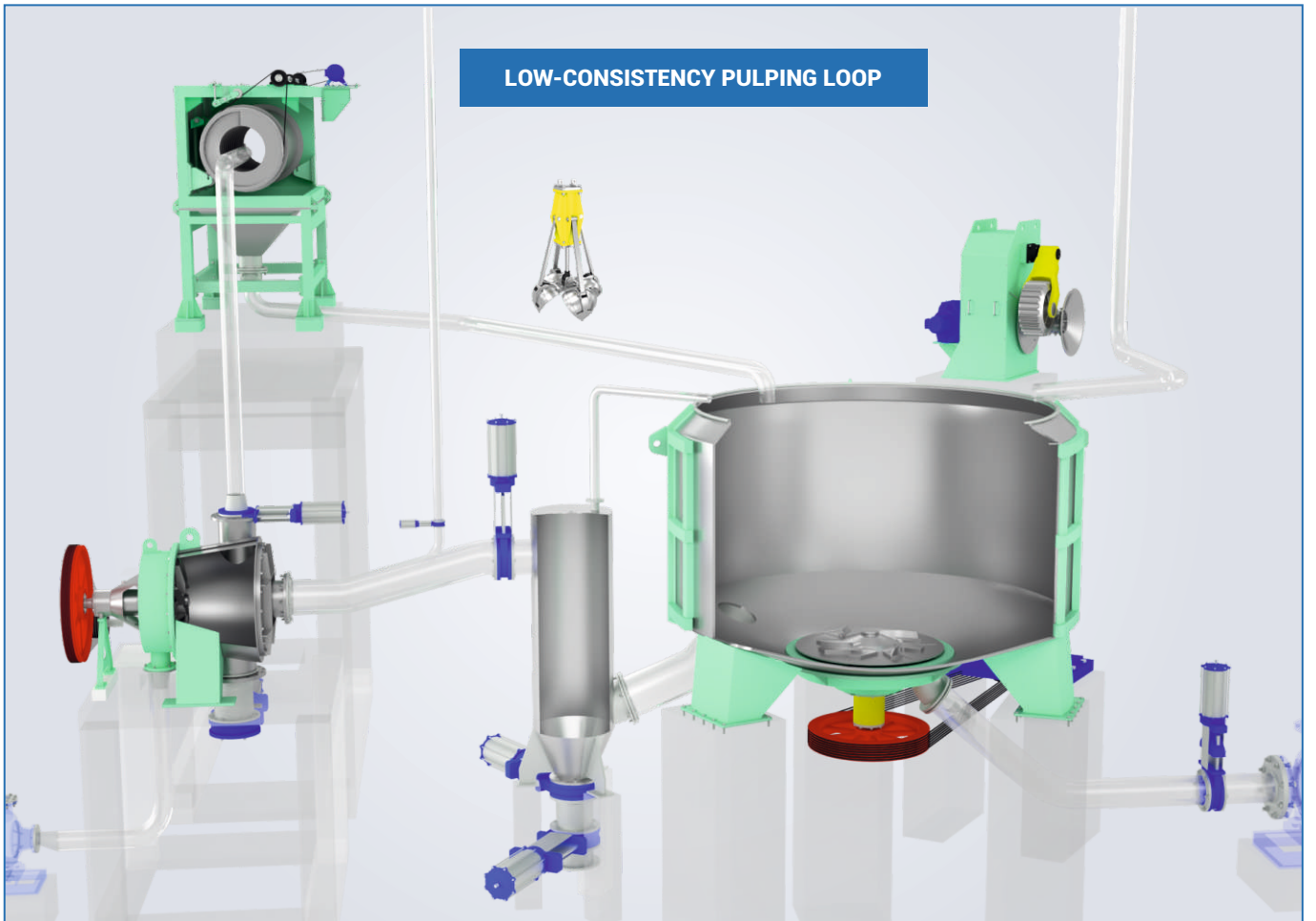

PARASON SHARPEDGE DRUM PULPER

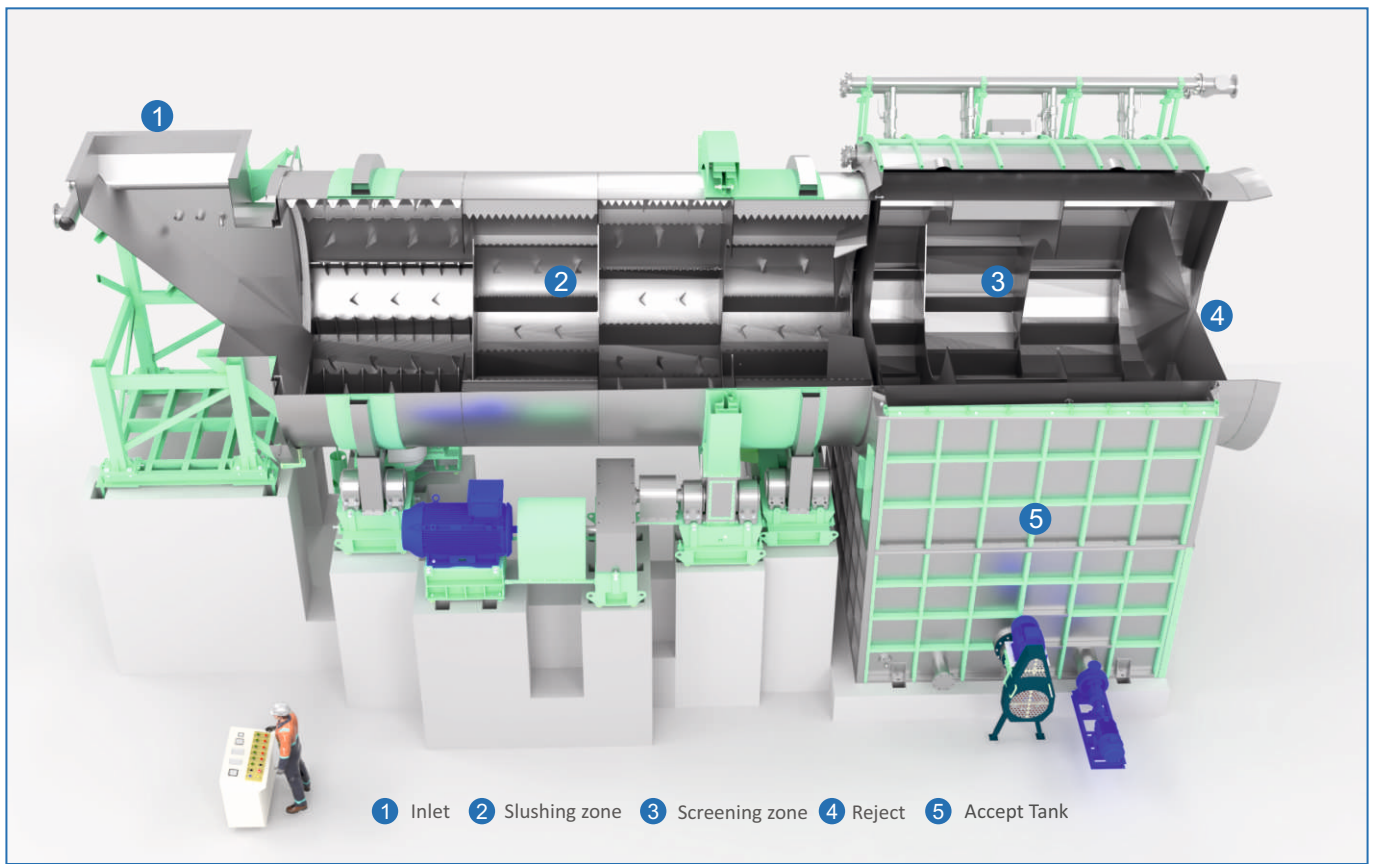

Parason SharpEdge Drum Pulper For Effective Fiber Treatment

Parason SharpEdge Drum Pulper follows an effective pulping process for recovered fibers that requires careful & gentle pulping to meet the various requirements of the paper industry.

Parason SharpEdge Drum Pulper is a machine developed for efficient pulping of stock consistencies up to 15% - 18% and for gentle and effective separation of fibers and contaminants.

Working Principle

Parason SharpEdge Drum Pulper uses the concept of a washing machine for its working. The HiTech Bar Knives Metallurgy is adopted for the first time in the world. It is a superb combination at a lower cost and reduced power in Refining process.

The pulp & the water are mixed and the concept of the Drum screen is used. The Drum Pulper consists of two zones: Slushing Zone and Screening Zone.

For writing printing paper, the slushing zone is divided into two parts and the screening zone is one part with one chest. For kraft paper, the slushing zone is one part, the slushing zone + screening zone is the second part, and the screening zone is the third part. It is supported by two chests.

Technical Specifications:

Installation size	PDP-15	PDP-30	PDP-45	PDP-60	PDP-80	PDP-100
Production (T/Day)	150	300	450	600	800	1000
Installed capacity [kW]	132	250	400	560	800	1000

Advantages

- It comes with a maintenance-free girth gear drive
- Elimination of tyres for the drive
- It uses the replaceable refiner plate bars with Parason ERP™ for slushing the pulp
- Manufacturing up to 1500 TPD of SharpEdge Drum Pulper
- Parason SharpEdge Drum Pulper can be used for Writing Printing, News Print, Kraft Paper, Low BF 14, 16, 18 BF of paper
- Low maintenance cost



SharpEdge Drum Pulper Reject with efficient removal of contaminants and minimum fiber loss

Features

- Standard diameter
- At this diameter, the pulp falling stock between 11 O'clock to 11.30 so that the maximum height is achieved
- The length of the Parason SharpEdge Drum Pulper varies as per the capacity
- Raw material flexibility: Slush highly contaminated recycled paper
- Gentle processing: Removal of an easy-to-slush fine fraction as soon as possible
- Operation with low net energy consumption between 15-25 kWh/t
- Low fiber loss due to non-shredding of contaminants
- Reduced power



Newly Developed Design

Parason SharpEdge Drum Pulper has Two zones

- Slushing zone
- Screening zone

Suitable for Writing Printing, News Print & Kraft Paper

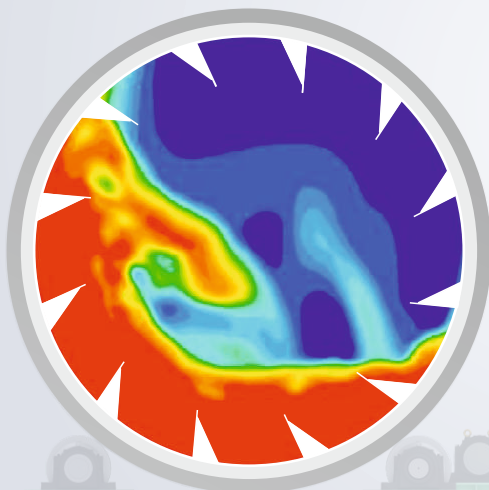

Sharp Knife
Edge Lifter

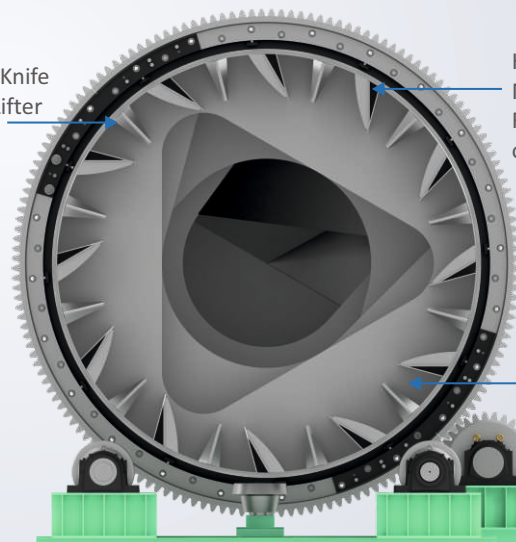

HiTech Bar
Metallurgy of
Refiner Plate
of Knives

Falling
stock

HI-CONSISTENCY PULPING LOOP

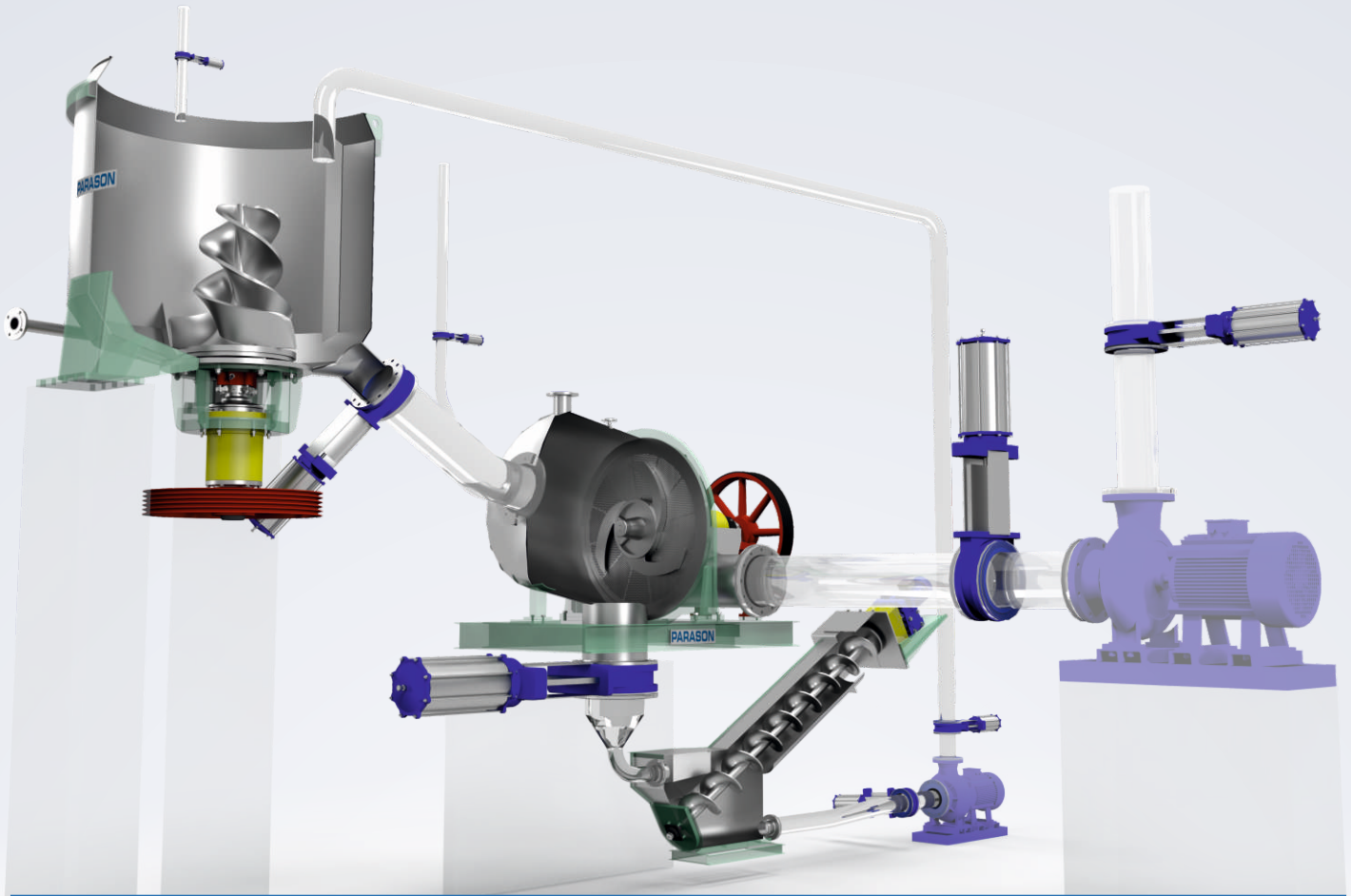

Hi-Consistency Pulping Loop

- 1 Hi-Con Pulper & Rotor
- 2 Dilution Pulper

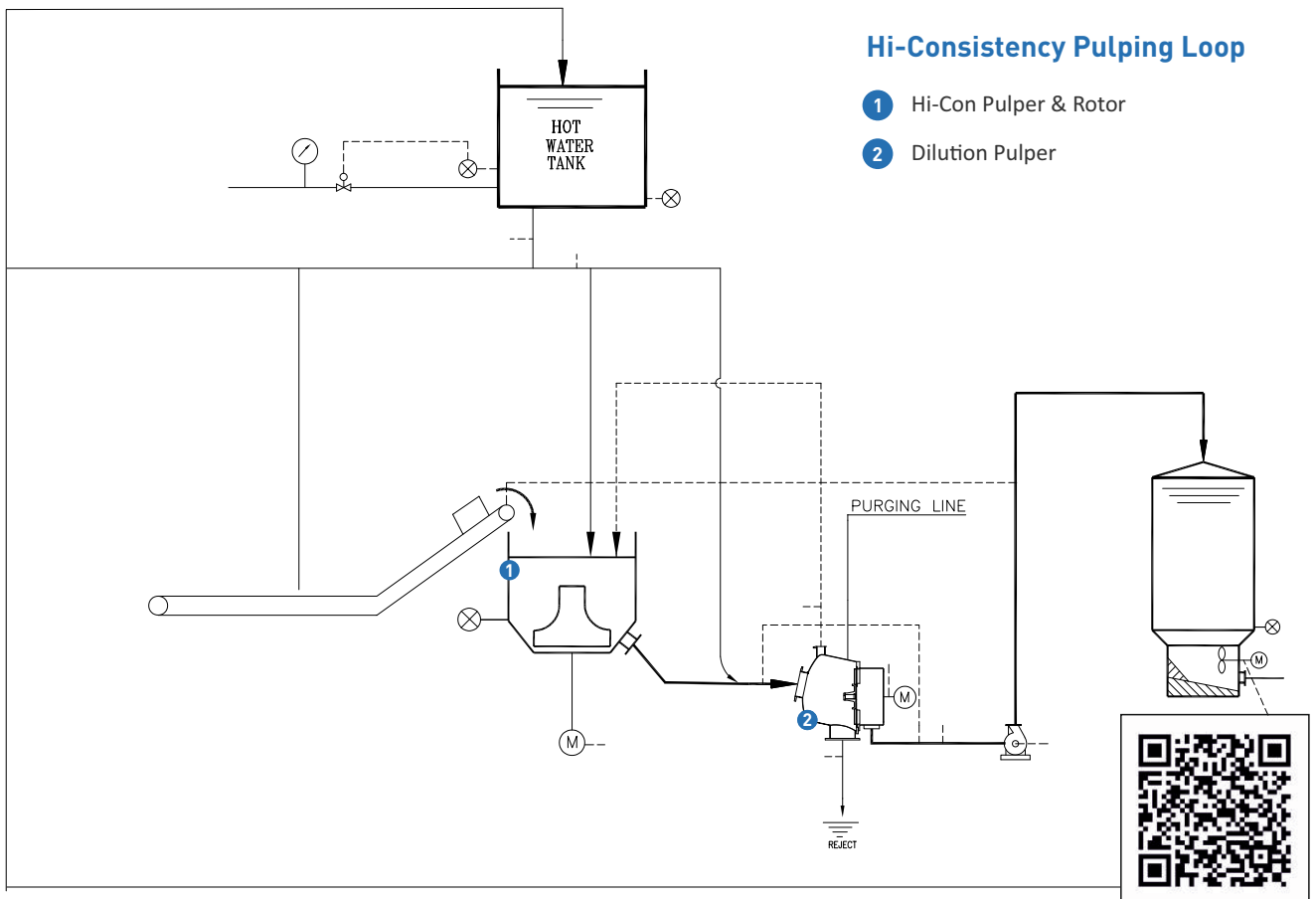

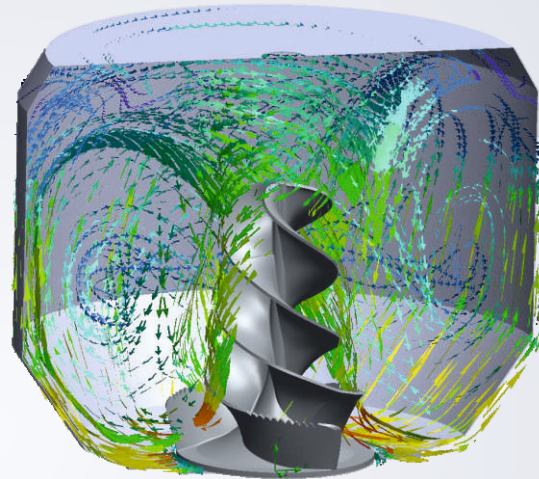
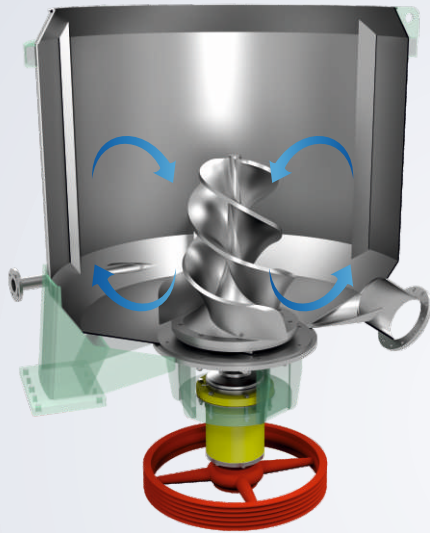

Results of flow simulation performed using latest computational fluid dynamics software

HI-CONSISTENCY PULPER

Versatile Equipment For

- Newsprint mills
- Writing & printing mills
- Board mills
- Kraft mills

ADVANTAGES OF PARASON CASTED HIGH CONSISTENCY ROTOR

<p>Cast Construction</p> <ul style="list-style-type: none"> → Helical design → Strongest construction → Homogenous microstructure from surface to core 	<p>Austenitic Stainless Steel Material of Construction</p> <ul style="list-style-type: none"> → Superior grade → Better toughness → Wear resistant 	<p>Profile and Geometry</p> <ul style="list-style-type: none"> → Perfect engineered contours → Unchanged geometry after long use
<p>Accurate Machining</p> <ul style="list-style-type: none"> → Zero eccentricity → Perfect right angle arrangement 	<p>Hardened Edges</p> <ul style="list-style-type: none"> → Uniform slushing → Long service life 	<p>Balancing</p> <ul style="list-style-type: none"> → Expert computerized system → Precision rotation
<p>Proven Technology</p> <ul style="list-style-type: none"> → Possible to slush wide range of raw materials → Helpfull in De-Inking 	<ul style="list-style-type: none"> → Uniform slushing 	<ul style="list-style-type: none"> → Low power consumption → Long Life

Technical Specifications:

Capacity (m ³)	4	5	6	8	10	12	15	**18	**22	**25	**30	**35	**40	**50
TPD	30	35	45	55	70	85	110	130	160	180	215	250	280	350
Power(kW)	90	100	110	160	200	220	315	335	400	450	550	600	700	800

* Production - TPD, Power kW depends on type of raw material cycle time, pulping time and technological properties

** Gear Drive | * Due to constant research, specifications are subject to change

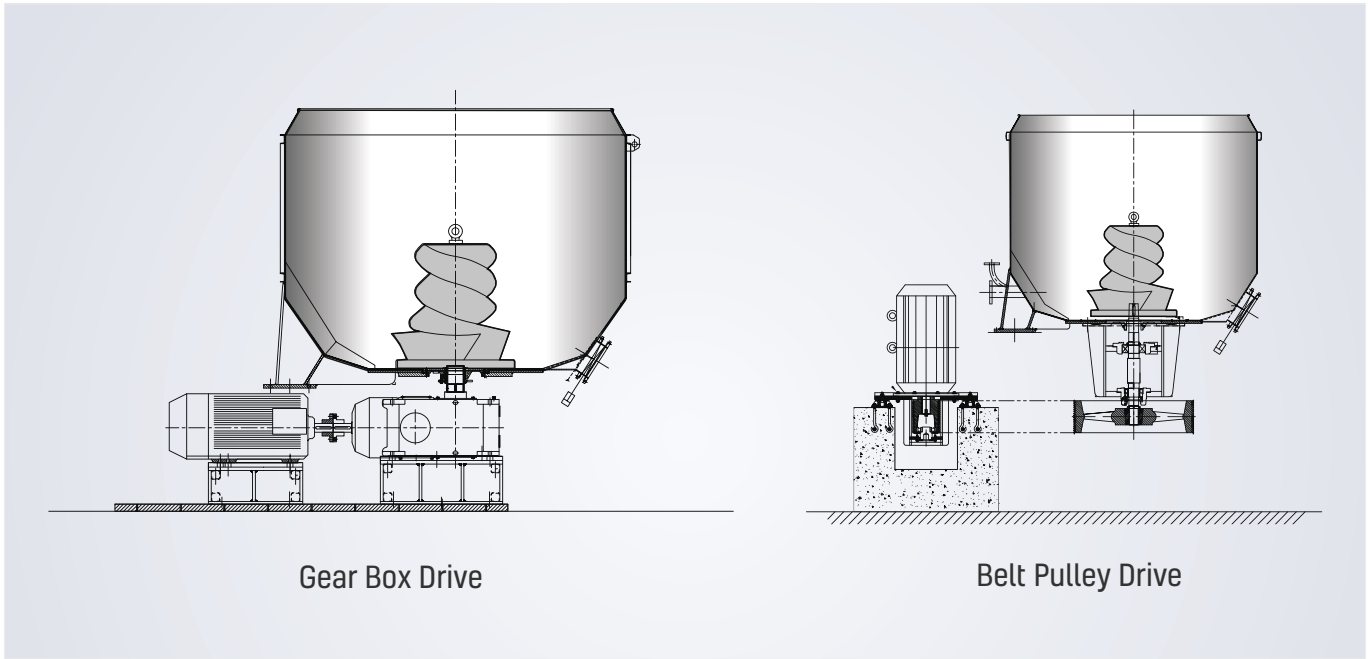

Efficient Removal of Contaminants

High Consistency pulping system is operated in batch process. The unique design of rotor creates excellent circulation within the vat and gives good slushing of raw materials, which permits operation at consistency up to 15%-16%. The Hi-con Pulper is suitable for all waste paper grades.

The discharge system is designed for discharging the high consistency stock from pulper diluting up to 4% and efficient removal of coarse contaminants. Benefits of high consistency pulper are high efficient ink detachment especially in writing and printing grade efficient slushing of fibers, gentle removal of contaminants.



Contaminants discharged from pulper



Pulper Inlet



Pulper Accepts

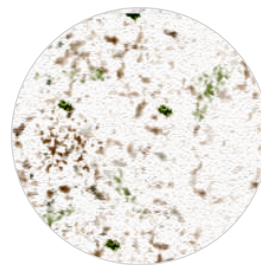

Pulper Inlet



Pulper Accepts

DILUTION PULPER

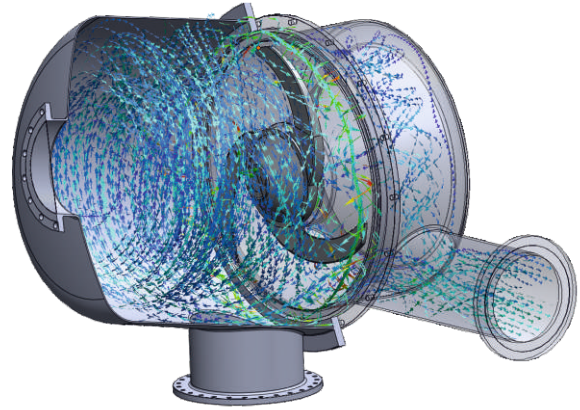
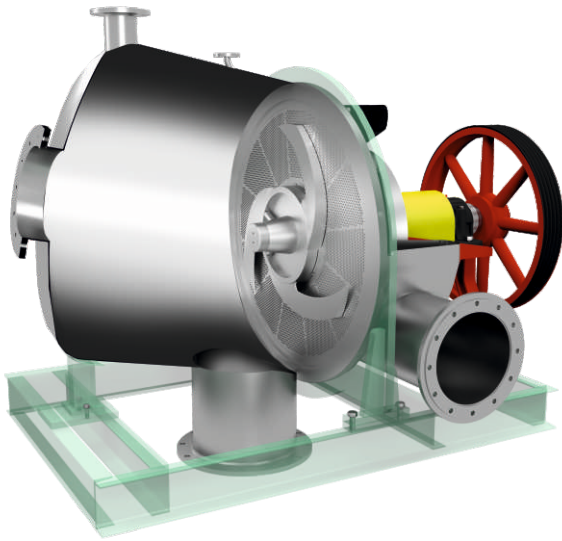

Results of flow simulation performed using latest computational fluid dynamics software

Application & Features

Hi-Consistency pulper is connected with dilution pulper. The dilution pulper has due function of separating the plastics and other foreign material and also dilute the high consistency for stock transfer for further processing.

This pulper has 6-8 mm drilled screen plate with impeller rotating against the screen. The impact of impeller separates fibre from the rejects, hence working most efficiently for fibre recovery.



PLC Panel

Advantages

- Uncut contaminants from Hi-Consistency Pulper are removed with negligible fibre loss
- The Hi-Consistency pulper become ready for next batch immediately after emptying out. The isolating valve isolates the dilution pulper from main pulper
- The dilution pulper works as first coarse screen thus reducing load on next stage equipment
- Removal of large foreign contaminants eliminates the risk of pulp jamming in successive operation

Technical Specifications:

DLP Model	7	9	12	15	18
Capacity (m ³)	0.5	1	2.3	4.5	6
Power (kW)	25	45	75	125	160

LOW-CONSISTENCY OFFSET PULPING LOOP

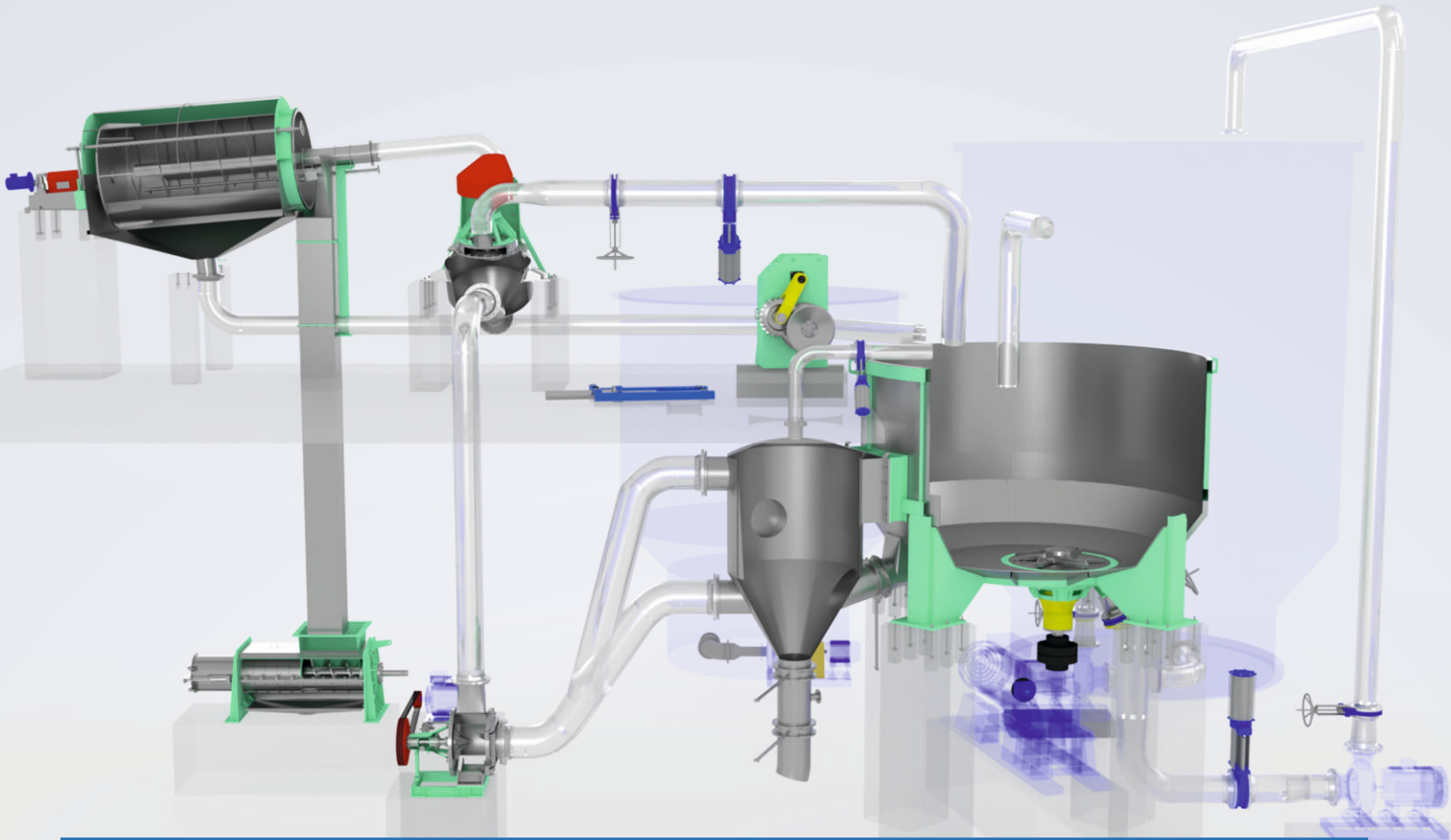

Low-Consistency Offset Pulping Loop

- 1 Offset Pulper
- 2 Sedi Trash
- 3 Reject Compactor
- 4 Trash Pump
- 5 Ragger
- 6 Rope Cutter
- 7 Asymmetric Fiber Saver
- 8 Inclined Trommel Screen

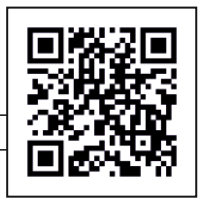
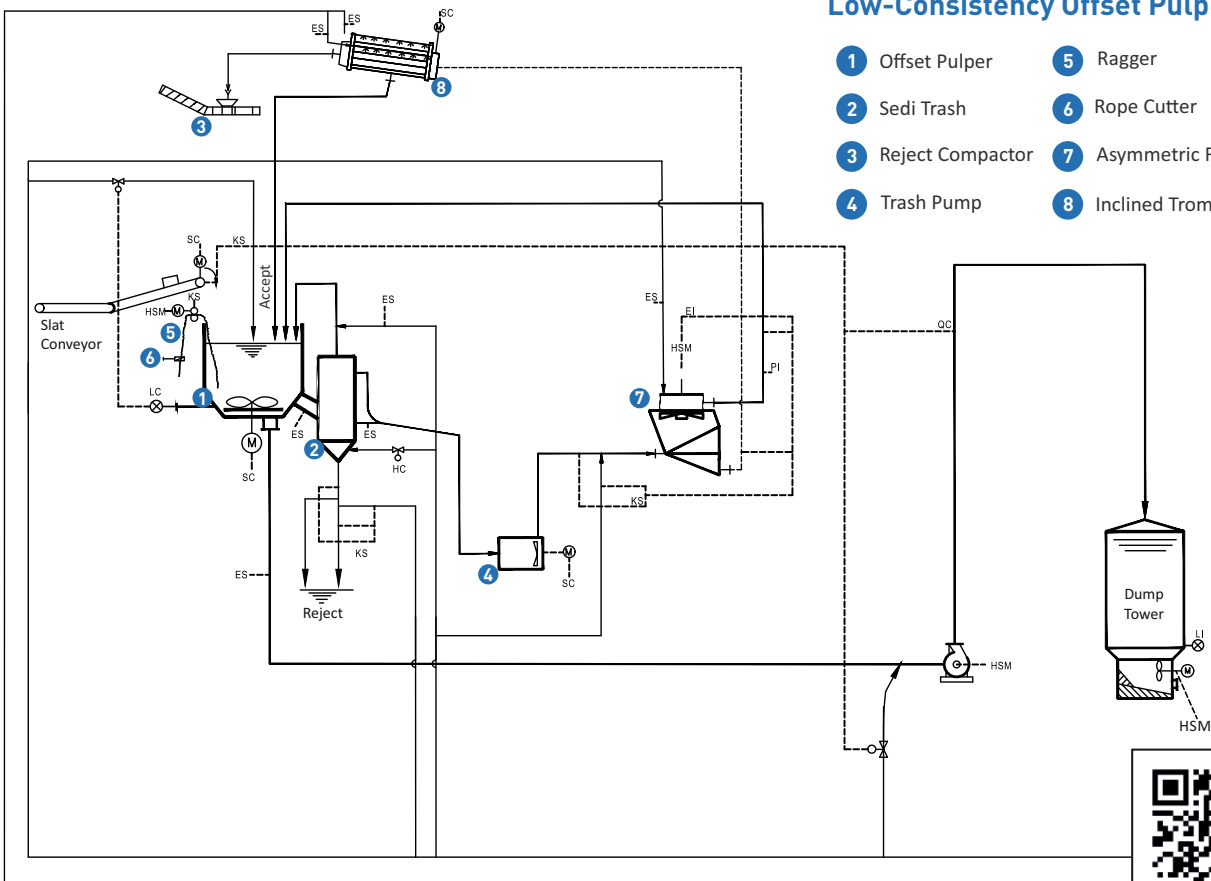

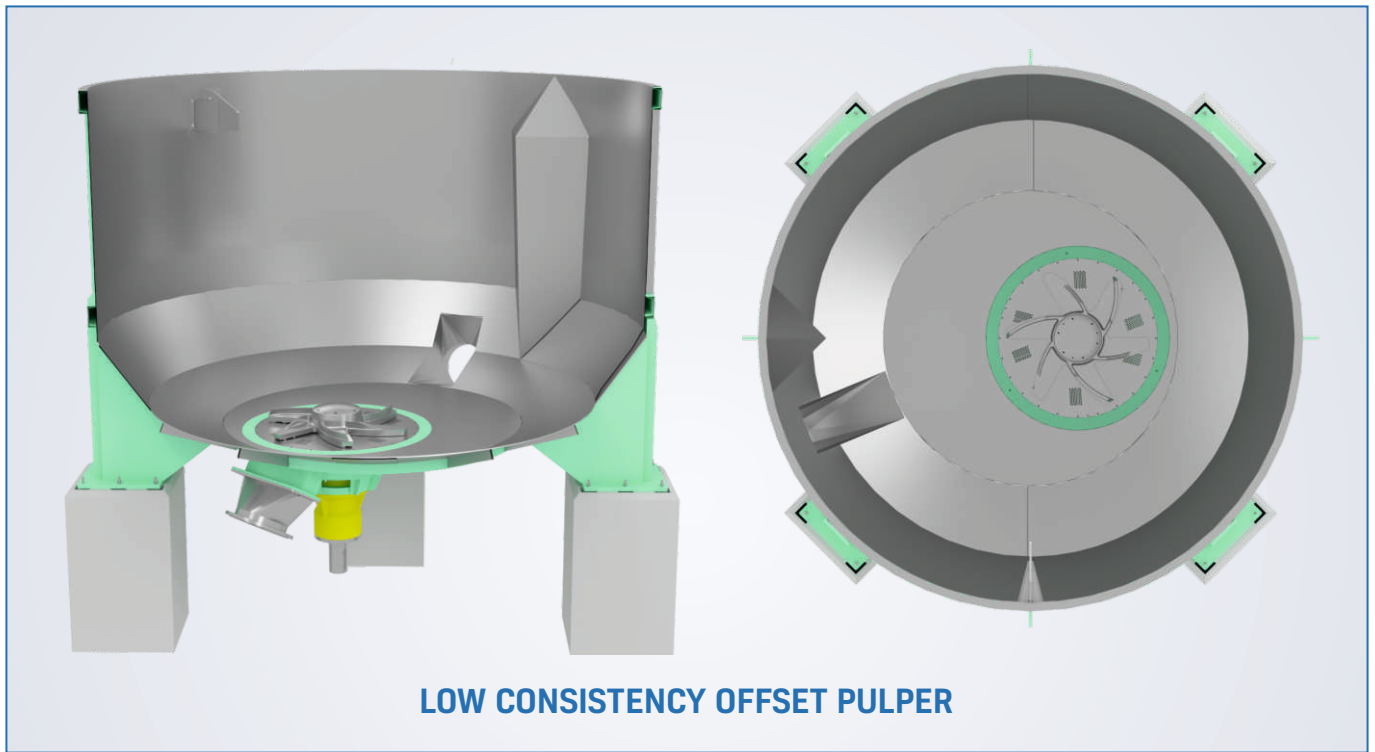

Working Principles

Parason newly developed Offset Pulper which is designed with a combination of double-coned bottom and baffle where the baffle guides the pulp towards the rotor for achieving efficient and extensive slushing. Intensive turbulence is generated on the part of the rotor, whereas low-level turbulence is generated at the baffle which causes the stock to rotate repeatedly thus obtaining excellent quality pulp.

The trouble-free ragger operation provides reliable operating conditions across large throughput. The combination of double-cone bottom & baffle pushes the core contaminants towards reject discharge.

Application & Features

- Offset pulping process for uniform pulp
- Improved throughput
- Double cone bottom provides excellent slushing
- Reliable ragger operation and low maintenance costs
- Improved removal of coarse rejects
- Specially built rotor for power-efficient pulping

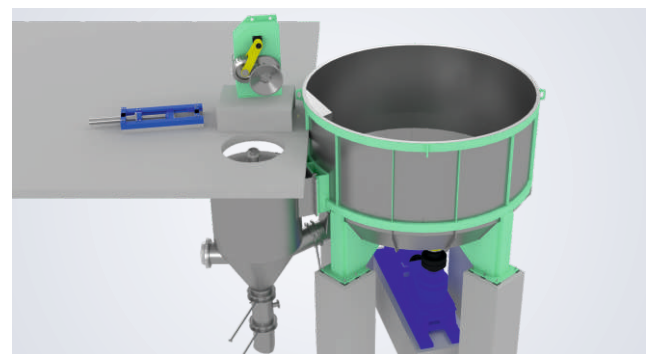

Technical Specifications

Motor RPM = 980

Capacity m ³	12	16	20	25	32	40
TPD	60 - 70	100 - 110	110 - 120	150 - 160	300 - 400	300 - 400
Power (kW)	110	150	180	250	355	400

Capacity m ³	50	73	95	120	145	170
TPD	400 - 450	600 - 650	700-750	900 - 950	1100 - 1150	1300 - 1400
Power (kW)	450	560	710	900	1100	1250

TRASH PUMP

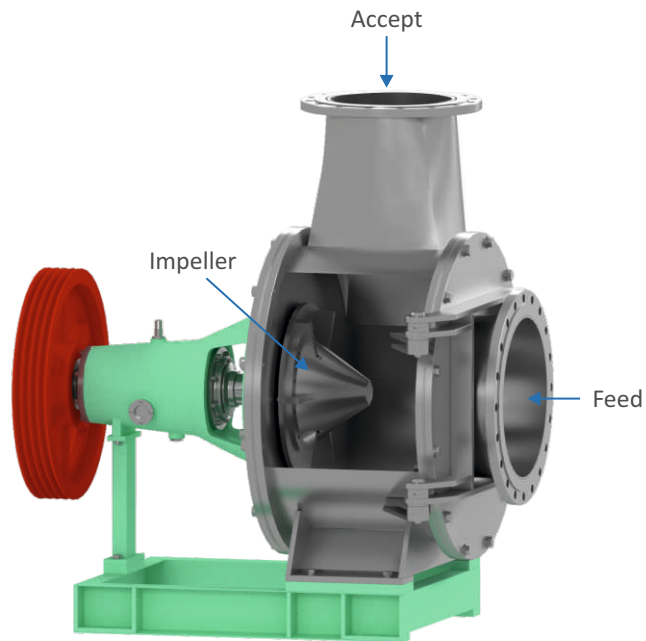

Application & Features

The main function of Parason Trash Pump is to efficiently move the rejects onwards to the Asymmetric Fiber Saver for further processing. Parason Trash Pump is designed so that it is perfect to be adjusted in smaller/tight locations. The drive unit of the Trash Pump is equipped with an impeller, mounting, belt drive, belt guard, and motor.

The Trash Pump consists of a housing with cover. This equipment is designed with a modern 3D technology approach and is targeted to perform more efficiently to gain extra productivity.

Advantages

- High-speed operation execution
- Easy to install
- Low maintenance requirements
- Lower power consumption & greater throughput
- Longer service life

Technical Specifications

PTP MODEL	PTP - 515	PTP - 650	PTP - 800
LPM	6000 - 7000	7000 - 10000	11000 - 15000
Power (kW)	55	75	110



ASYMMETRIC FIBER SAVER

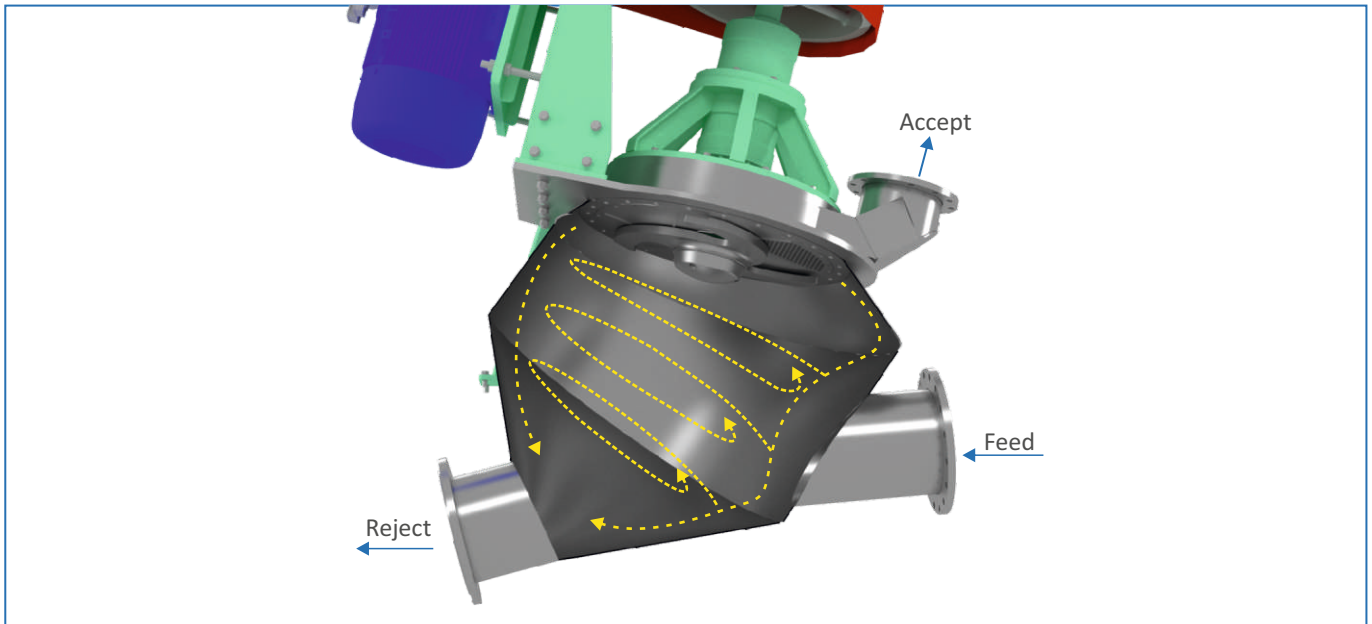

Application & Features

Parason Asymmetric Fiber Saver (AFS) is a pulper detrashing machine for both low-consistency pulper and high-consistency batch pulper. In the Asymmetric Fiber Saver, the rotor screen unit is arranged Offsetally to the asymmetrical machine housing. The specially designed Parason AFS is capable of removing up to 70% contaminants from the pulp.

The equipment maintains stable trouble-free production at the pulper loop thus reducing the load on the pulper. The asymmetric design helps to omit the blockages, reduce wear resistance and rotor damage which also makes it difficult for the big-sized contaminants to flow against gravity.

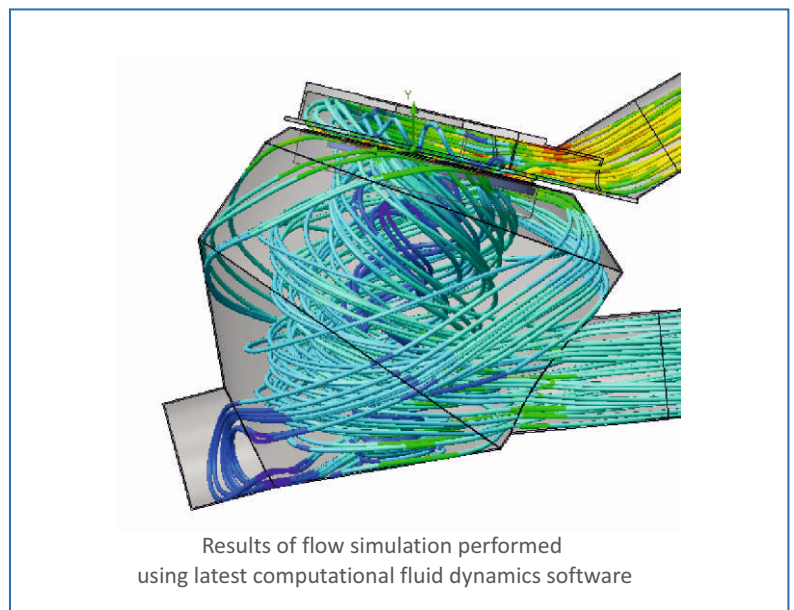

Key Benefits:

- Reduces fiber loss in the pulping process
- Efficient & power saving process
- Minimum maintenance requirements
- Trouble-free operation
- Longer service life

Technical Specifications

AFS Model	AFS - 08	AFS - 15	AFS - 30
Volume (m ³)	0.8	1.5	3
Power (kW)	55	75	110

INCLINED TROMMEL SCREEN

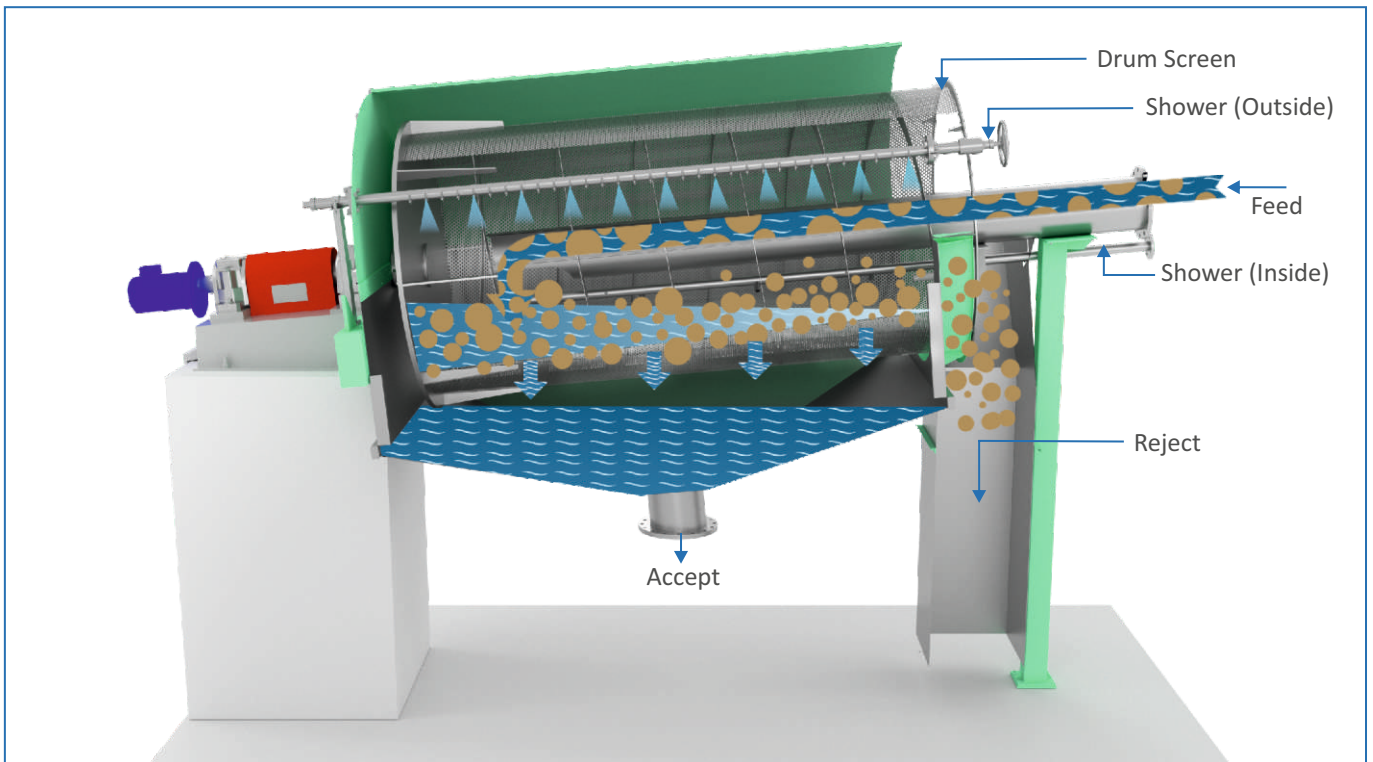

Application & Features

Parason Inclined Trommel Screen is manufactured with the highest standards for efficient removal of the coarse debris and for maximizing water recovery from the reject loop. The technology used behind the Inclined Trommel Screen optimizes the rejects residence time and increases fiber gain and water recovery.

Parason Trommel Screen is capable of handling any amount of production rate and quantity. This equipment is built considering the low power requirement and more output efficiency resulting in the long run of the machine. All wetted parts are made up of stainless steel.

Advantages

- Efficiently removes coarse debris
- Maximizes water recovery from reject loop
- Optimizes the rejects residence time
- Increases fiber recovery
- Suited for both batch and continuous operations

Benefits

- Guaranteed improved performance
- Low maintenance requirements
- Low power requirements
- Easy operating methods
- More productive and cost-effective

Technical Specifications

ITR MODEL	ITR 1.25	ITR 1.6	ITR 2.0	ITR 2.5
Throughput (l/min)	3480	5820	9000	12300
Power (kW)	7.5	7.5	11	15

REJECT COMPACTOR

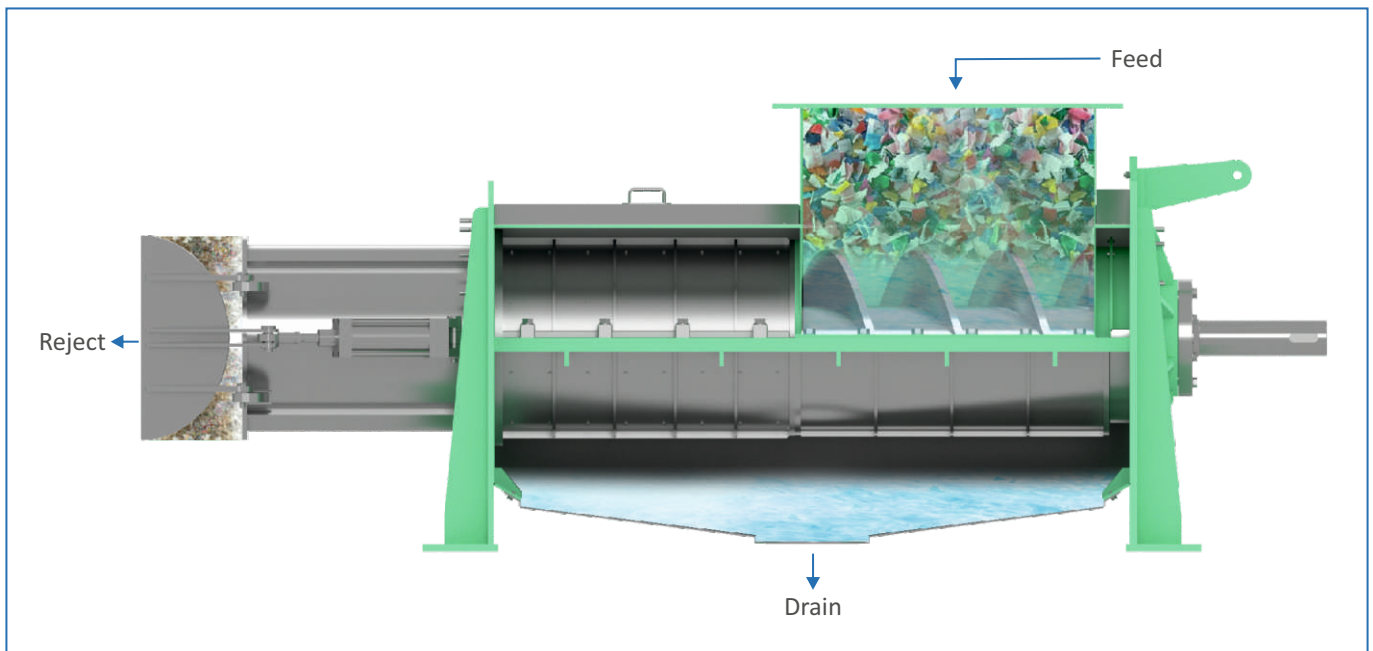

Purpose

Parason Reject Compactor is built for separating rejects of variable particle sizes containing a significant amount of fibers.

Rejects like pieces of plastic, laminated paper, wood particles, textile pieces, stickies, wax, sand particles, glass pieces, metal particles, etc. are efficiently separated with the Reject Compactor.

Process

The reject fed to the compactor is conveyed by a rotating screw. The hydraulically actuated pressure hatches compress the reject material inside a counter-pressure unit.

The heavy-duty & wear resistance baskets retain the solid particles and the water is allowed to flow down through the holes. Parason Reject Compactor can efficiently achieve maximum dryness.

Key Benefits

- Works with smaller to higher consistencies i.e. 10%-45%
- Design is suitable for both lower and higher consistency operations
- Lower maintenance cost & longer service time
- Improved quality of accepts obtained with negligible fiber loss

Technical Specifications:

PRC Model	PRC 400	PRC 600
Power (kW)	15	20

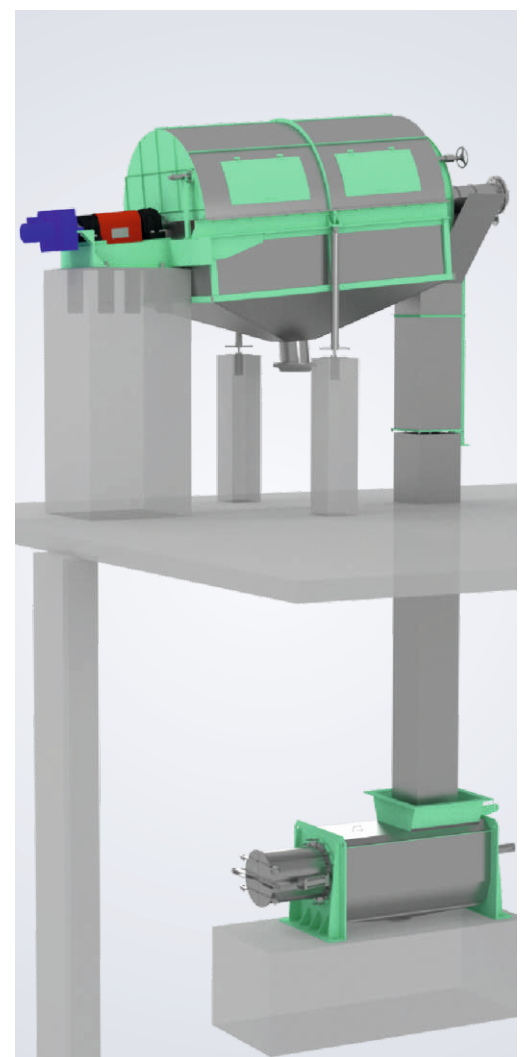

Requirement: A Pulper to handle recycled waste paper with heavy contaminants

Parason 'O' Type Pulper is designed to treat all types of recycled papers.

Parason LCO Pulper is equipped with a rotor and vat to provide high pulping efficiency that guarantees gentle treatment of fibers. LCO Pulper makes the handling of contaminants easy with its fiber guarded detraghing system. Parason LCO Pulper comes with low rotational speed and a fast reject removal system that ensures the longer lifetime of each component.

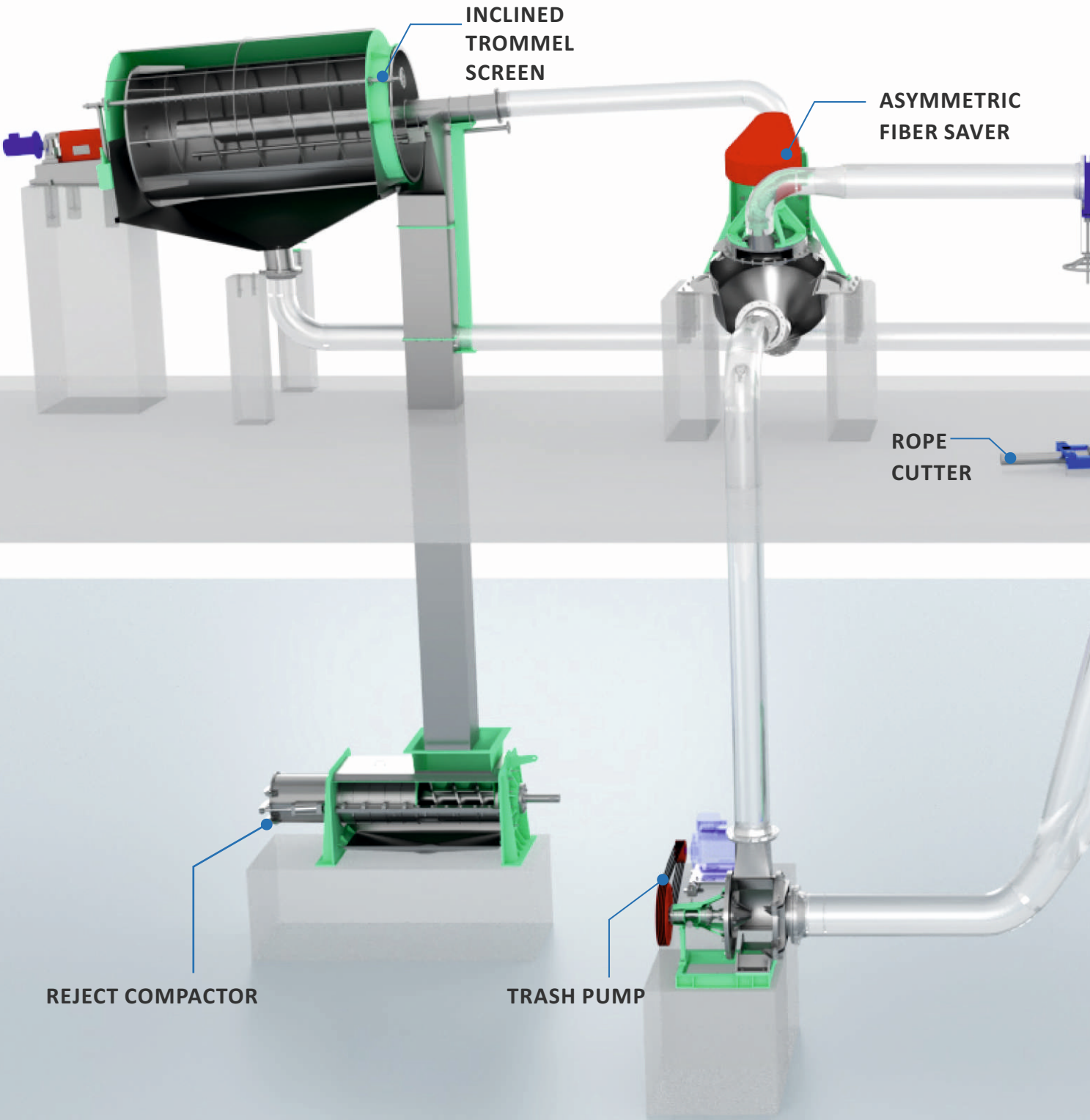

Solution: Parason Low Consistency Offset Pulper is specially developed with fiber guarded detrashing system to handle heavily contaminated recycled pulp

- Improved quality of pulp due to early removal of non-disintegrated reject materials and quick forward of accepts
- Reduced power consumption
- Lower space requirements due to the compact design of machine and components



LOW-CONSISTENCY PULPING LOOP

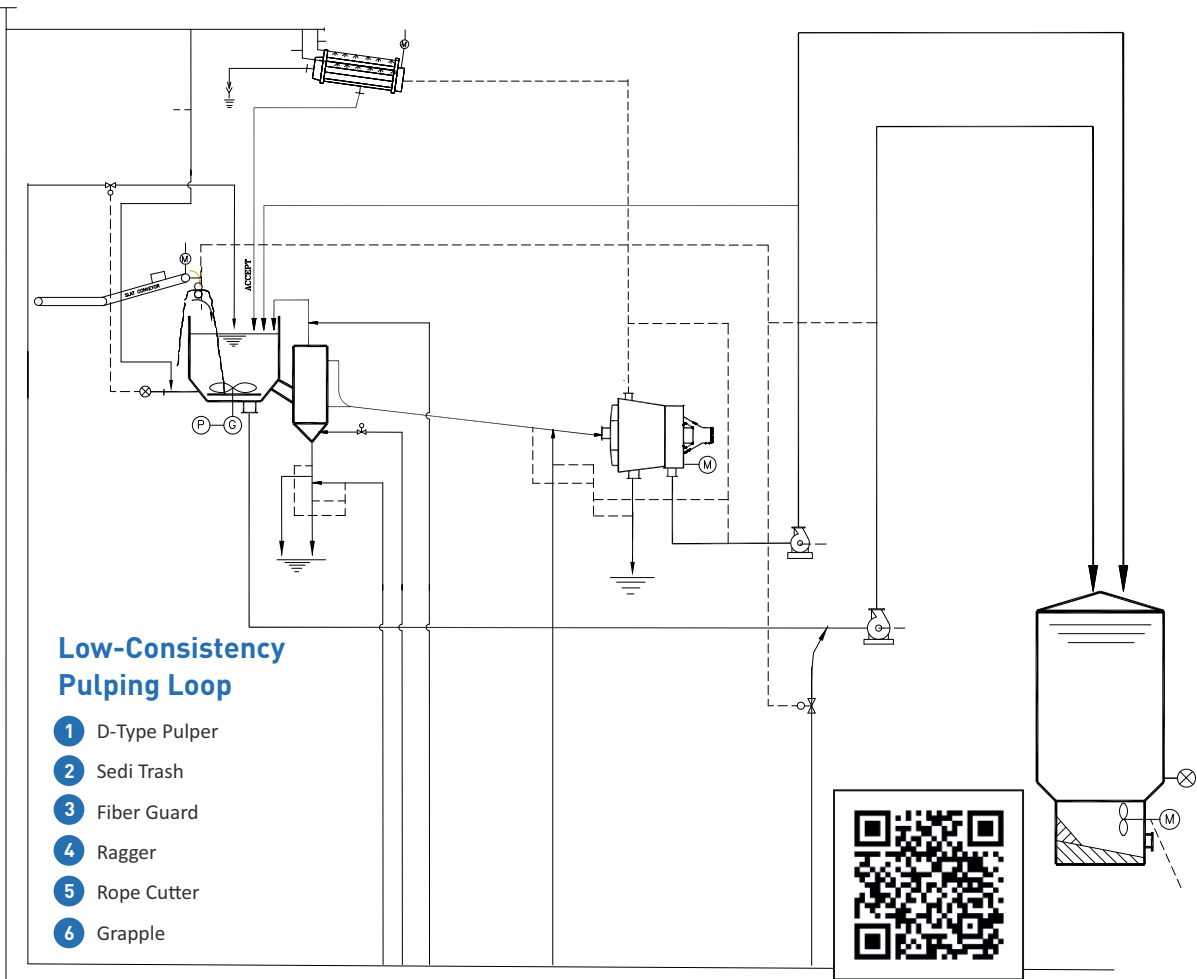
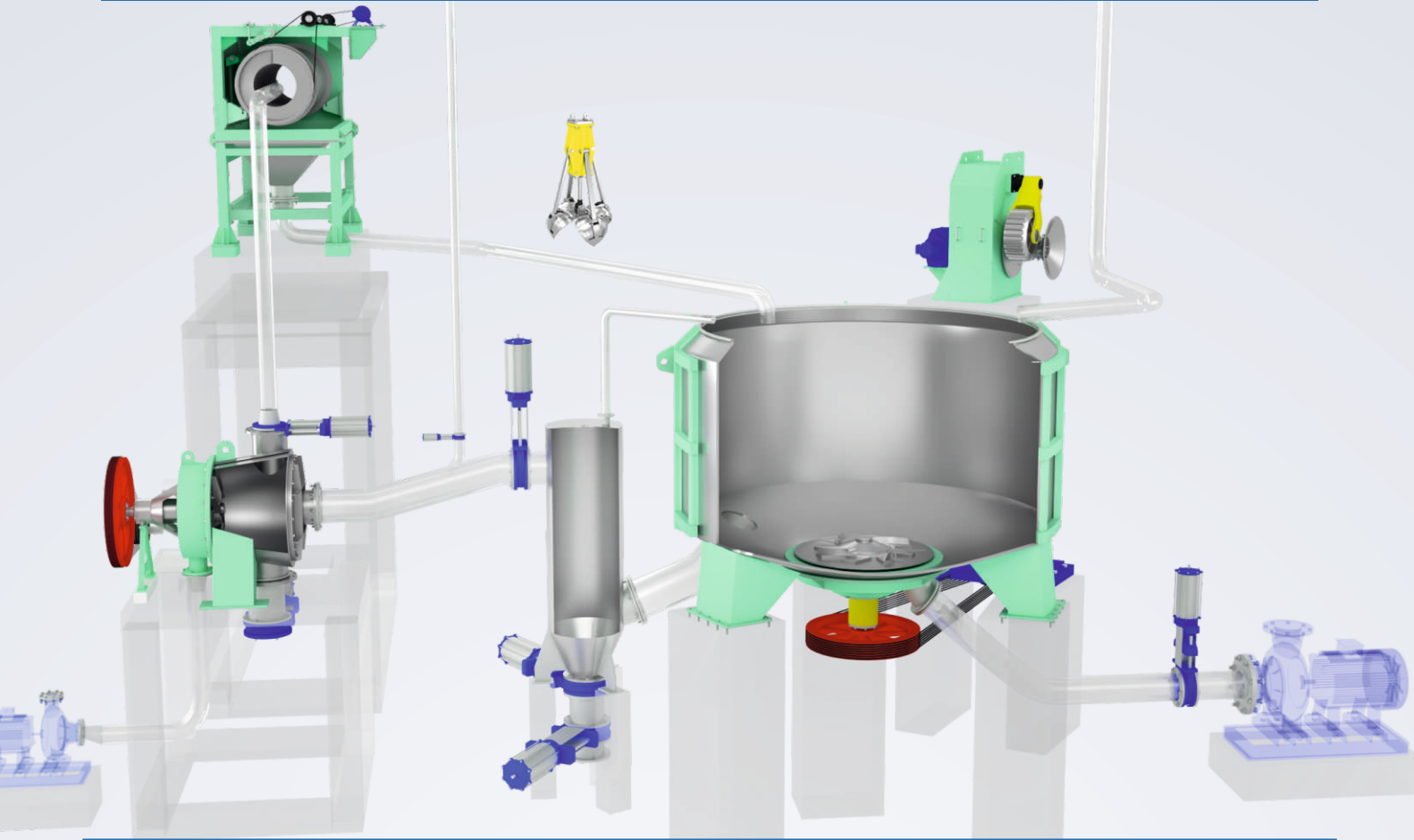

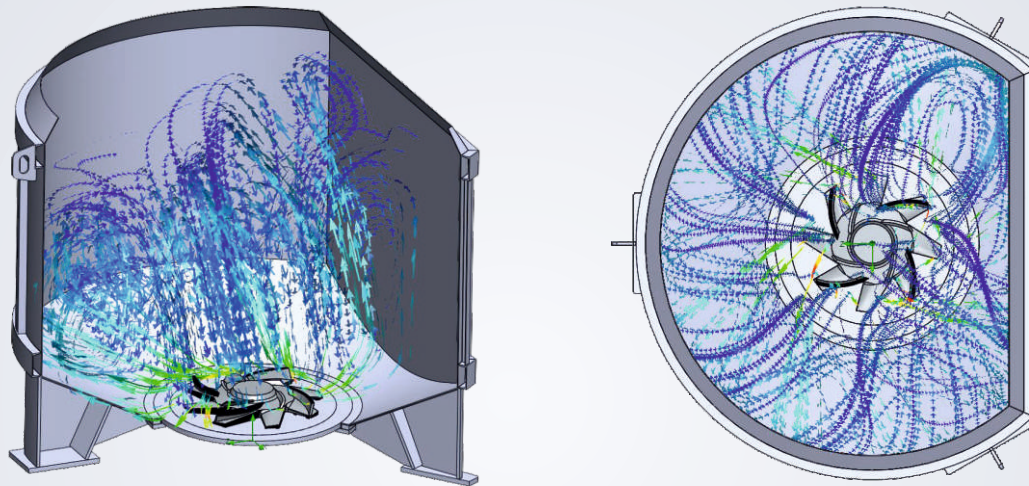

Results of flow simulation performed using latest computational fluid dynamics software

LOW CONSISTENCY D-TYPE PULPER

Operating Principles

'D' Section of tub is to increase the turbulence in the tub causing bales/bundles to submerge rapidly thus, reducing the dwelling time suitable for continuous operations. Suitable for furnish of OCC, AOCC, Box Board and to separate the reject and fibre. The fibre discharge line is connected to the pulp suction pump or directly fed to the storage towers.

Application & Features

- The model 'D' refers to the shape of Tub
- Continuous operation
- Operating consistency 4-6%
- Higher capacity (TPD) with reduced power input compared to normal vertical pulper
- S.S. Cast Rotor of special design for handling different grade of raw material
- 'D' Pulper can be operated at ambient temp. as well as at elevated temp. upto 70°C
- Heavy duty sturdy bearings take impact load of bales/waste paper bundles
- Removes plastic in large pieces with little degradation
- Reduce burden on downstream equipment
- Decreases/eliminates clean out down time

Technical Specification

Motor RPM = 980

Capacity m ³	6	8	10	12	16	20	22
TPD	25-30	40-50	70-75	70-90	110-120	140-150	150-160
Power (kw)	75	90	110	132	150	200	220
Capacity m ³	26	32	35	40	50	60	70
TPD	200-250	250-300	300-330	350-400	400-450	450-500	600-650
Power (kw)	250	315	355	400	450	550	600

RAGGER

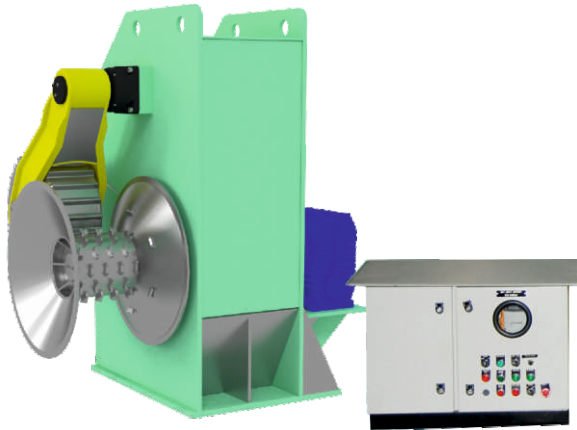

Parason Ragger removing contaminants from the pulp with Ragger Rope

Application & Features

In series with the Pulper, the newly developed Ragger by Parason is efficient in easy and effective removal of contaminants like wires, rags, strings, plastics with the help of Ragger rope. The Ragger is easy to install with both horizontal and vertical types of pulpers. The time delay between the running of motors is adjustable as per your convenience. The speed of Ragger operation can be set as per the level of contaminants and production rate. Pneumatic loading and relieving of the loading rope are available.

Ragger control panel is designed for

- Extra safe for removing contaminants from pulper
- Maximum profile contact allows robust and reliable removal of spinning contaminants
- Automatic loading & lifting of roller
- Easy adjustments with emergency stops
- Visual indications of Ragger motor 'ON' & air pressure



Technical Specifications

PRG Model	PRG - 250	PRG - 450	PRG - 700
RPM	0 - 3	0 - 3	0 - 3
Geared Motor	0.75	1.1	2.2

ROPE CUTER

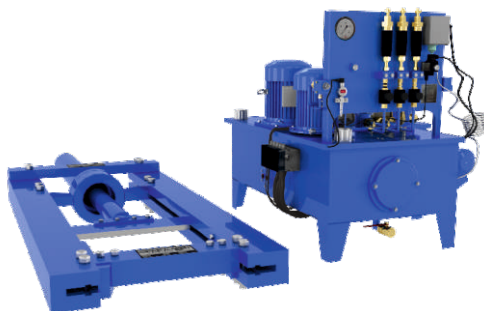

It is an integral part of Ragger system whereby the ragger rope string is cut at regular interval

Application & Salient Features

- Used for cutting ragger rope
- Double acting hydraulic cylinders give it a strong cutting ability

PARASON FIBER GUARD

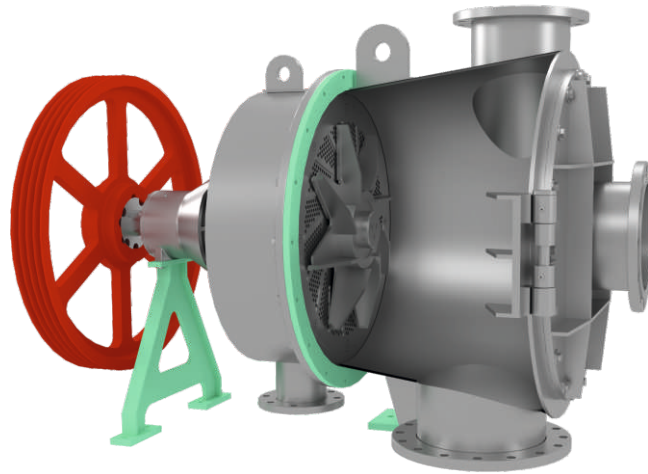

Application & Features

Parason Fiber Guard is extensive equipment that gives effective separation of contaminants from the stock suspension. The stock with impurities and contaminants is transferred from the pulper to the Fiber Guard. Fiber Guard works on the pressure produced by the rotor and effectively separates contaminants and forwards the stock to the screening of disintegrated fibers.

Advantages

- Fiber Guard is specially used for wet preparation of the waste paper
- Impurities are removed with negligible fiber loss
- Prevents pulp jamming in successive operations
- Energy-efficient, cost-saving, & low maintenance

Technical Specifications

Motor RPM = 1470

PFG MODEL	PFG - 01	PFG - 02
Capacity (m ³)	12	11
Power(kw)	90	160

GRAPPLE



Grapple is mainly used in continuous pulping system for grappling heavy and large impurities from sediment well.

Application & Salient Features

- Mainly used for grappling heavy and large impurities from sediment well
- “Four petal” air pressure type operation
- Easy to maintain and operate
- Adopts stainless steel material, long service life

TROMMEL SCREEN

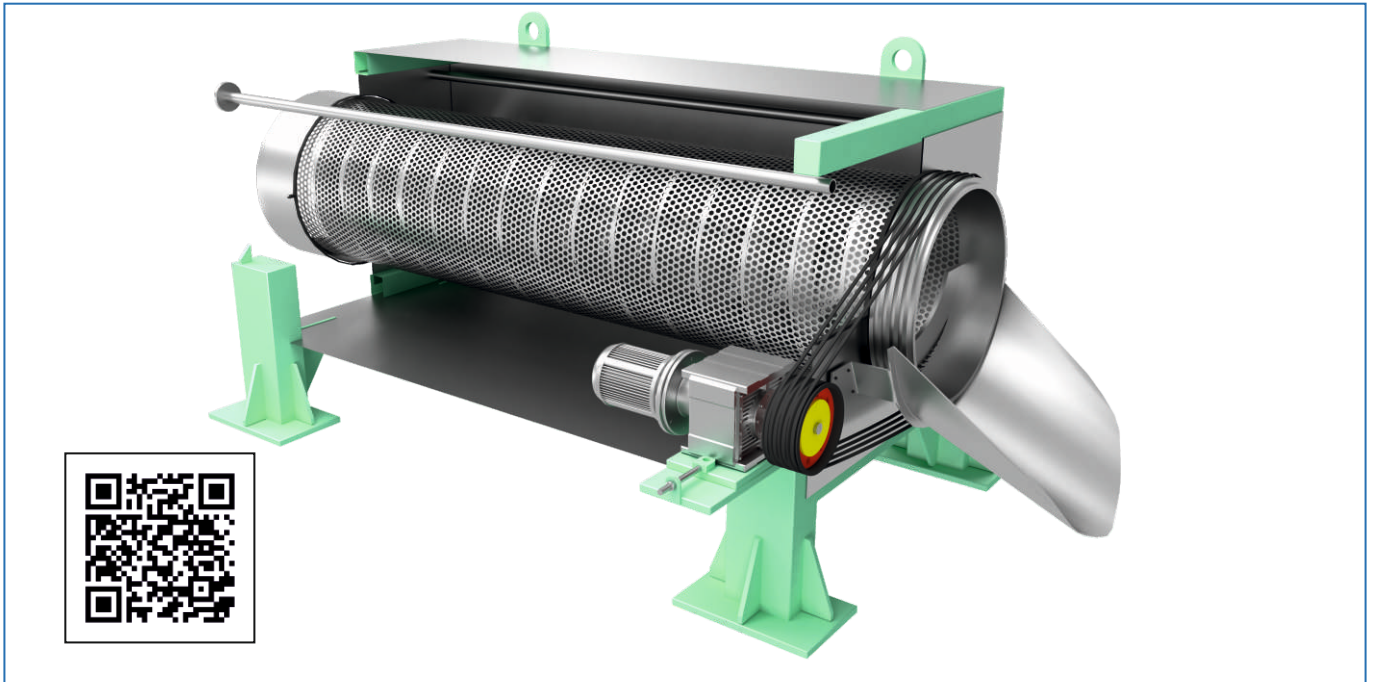

Application & Features

To lessen the contaminant load on Fibre Saver (PFS), the light rejects normally directed to Trommel Screen. Special heavy duty perforated drum with hole size in ascending order and aided by suitable shower inside & outside allowing the recovery of fibres.

The coarse contaminants get rejected and accept is returned to the pulper.

Advantages

- Easy Installation
- Perforated drum of SS-304, drive arrangement, inside helical screw, out let chute of SS-304
- Drum is driven through Geared Motor, Pulleys and Belts
- CI drive and driven pulleys properly machined
- Shower pipe with nozzles of SS-304



Technical Specification

MOTOR RPM = 1500

TSR MODEL	1	2	3	4	7
TPD	8-15	15-20	20-25	25-30	35-40
POWER(KW)	3.7	5.5	7.5	9.5	11

PARASON UNDER PULPER (UTM)

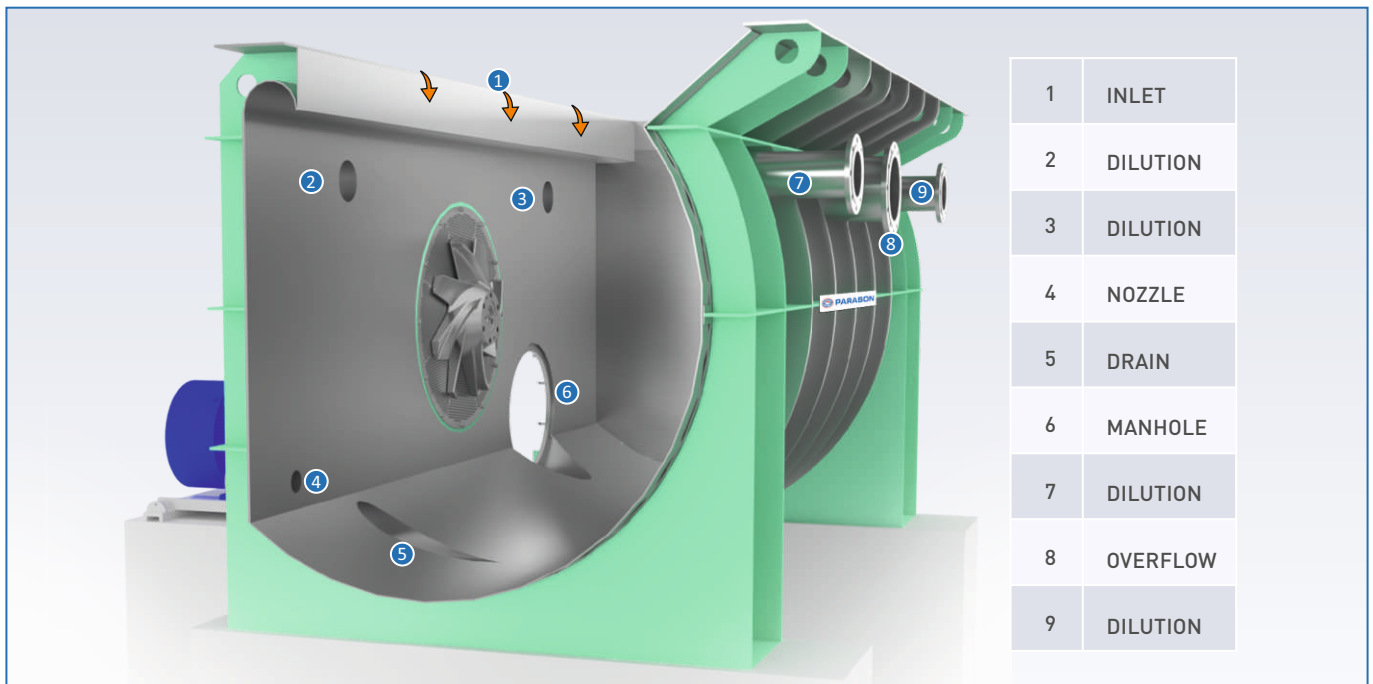

Use PUP for higher capacity & higher consistency pulping

Parason Under Pulper (PUP) is a solution developed with proven & reliable technology for higher capacity and higher consistency pulping needs. The vat is designed such as to improve the pulp circulation and achieve a better deflaking effect.

The rotor is fixed in the accept chamber with a perforated screen plate and discharge nozzle. The operation is based on active circulation with the help of pumping vanes and deflaking using spoke vanes.

Feature

- Optimum rotor size for excellent slushing
- Suitable for dry broke and press broke
- 3% - 6% pulp consistency with lower power consumption
- Compact design with low VAT height for effective slushing

Applications

- Slushing wet strength, board, coated, and special grades/slabs
- Higher capacity operations
- Suitable for high consistency pulping requirements

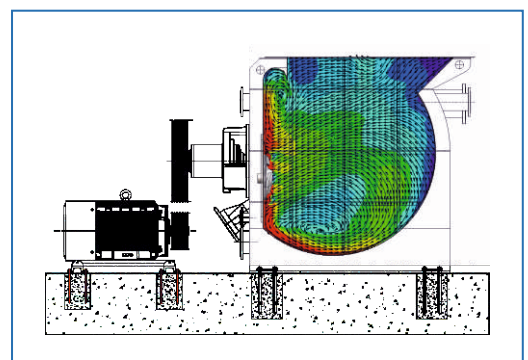

Technical Specifications

PUP Model	PUP - 24	PUP - 33	PUP - 42	PUP - 50	PUP - 63
Rotor Dia (mm)	610	845	1060	1270	1600
Power (kW)	30 - 90	75 - 200	110 - 400	132 - 500	250 - 710

AUTOMATION SOLUTIONS FOR PULP & PAPER

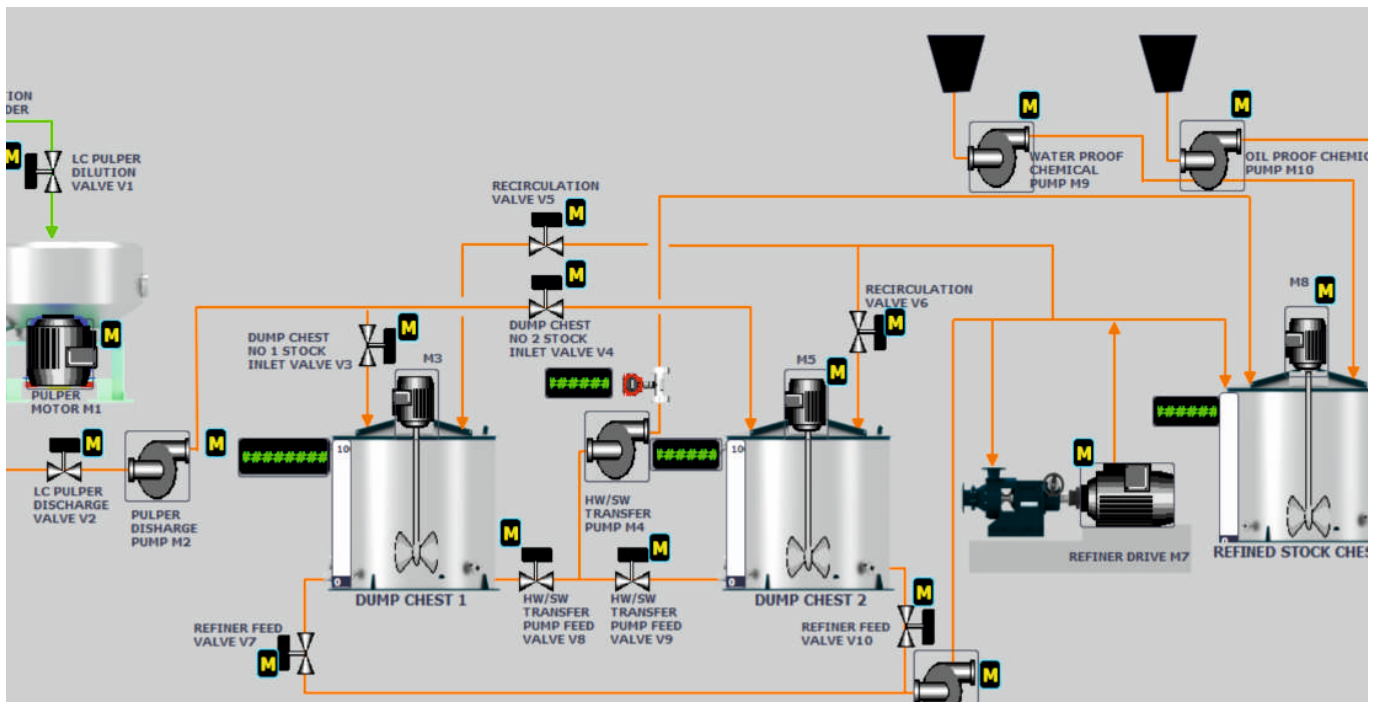

Parason has installed more than 405+ Pulp line in India & abroad. Parason has pleasure to introduce Automation division and are committed to serve Pulp and Paper industry.

We are offering complete line of automation services. Parasons product-lines are being equipped with PLC control panel as standard, with option of DCS interfacing to achieve automated sequences for operation, start-ups and shutdowns. The logics are designed by well experienced team and include safety interlocks, event & alarm lists, fault handling routines and Diagnosis features. The Hardware is field proven, state of the art.

We offers

- Automation System design, selection and supply.
- Field instrumentation selection and supply.
- Pneumatic and Hydraulics design and supply.
- Services of Erection & Commissioning, Optimization.
- Electrical Interfacing with Drives, MCC etc.
- Instrument Networking, interface with Mill ERP through OPC for regular reporting and mobile alert etc.

Automation Advantages by us

- Increased production.
- Uniform product quality.
- Lower breakdowns, down time.
- Quick Diagnosis of problems.
- Early recovery from plant upsets.
- Viable and Early Return Of Investment.



DCS



PLC



Field Instruments

Providing complete Turnkey solution from 50 TPD to 1000+ TPD

We serve to the Pulp & Paper industries with our best customized engineered solutions for every requirement

Delivering quality services with a profusion of experience in various fields of the paper industry

We believe in providing premium solutions to our customers that will help you maintain an edge over the market

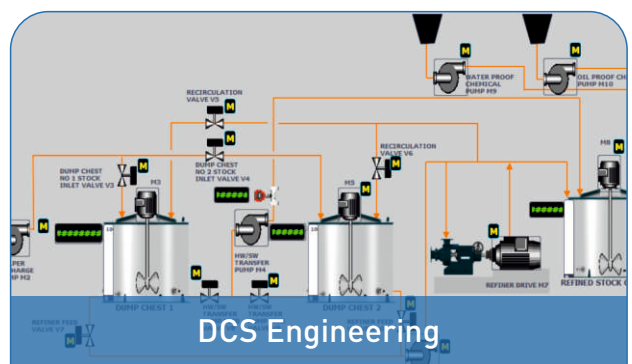
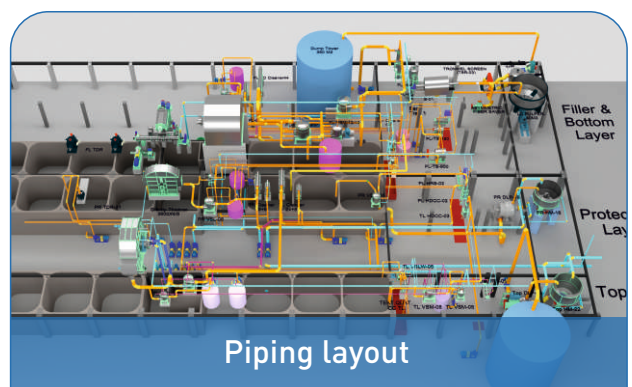
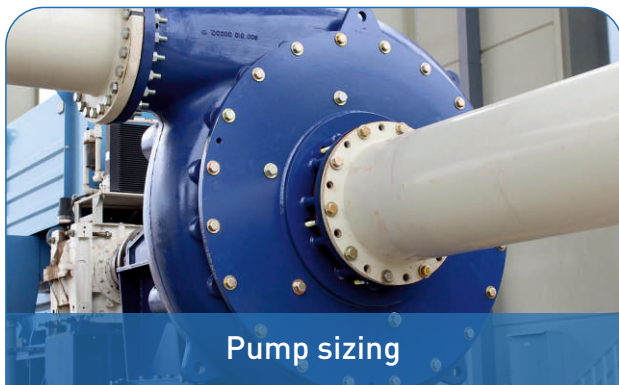
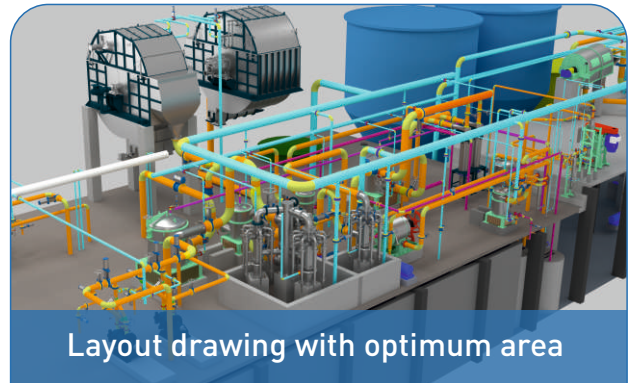

GENUINE SPARE PARTS

GUARANTEES THE BEST PERFORMANCE

Manufactured with CNC machines to ensure high accuracy

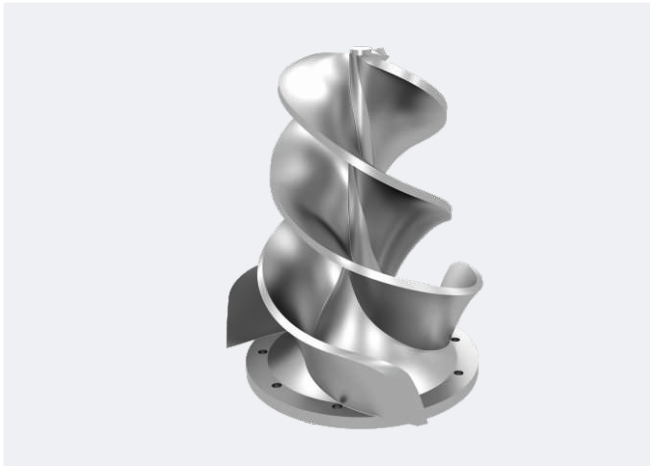

HC Rotor



LCO Rotor



Impeller



Fibre Saver Impeller



AFS Rotor



Dynamo Rotor Series



Shaft Sleeve

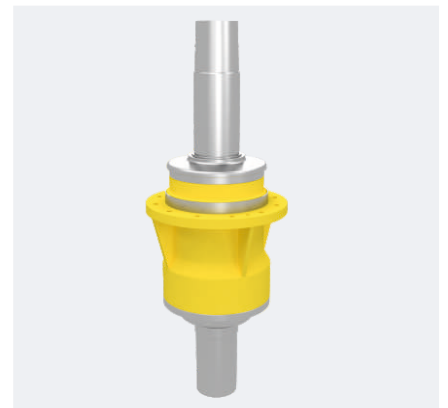

Rotating Assembly For
LC Pulper & Fibre Saver



**BIGGEST DIAMETER ROTOR (Ø2150 MM)
NOW AVAILABLE**

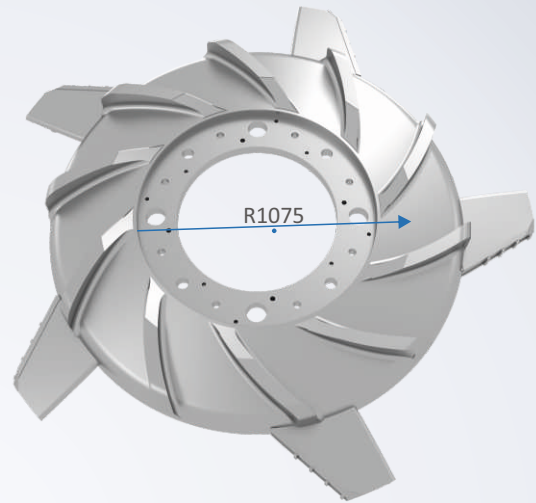

Rotor for 70m³ Pulper
MOC: Duplex 2205 (Weight 1000 kg)

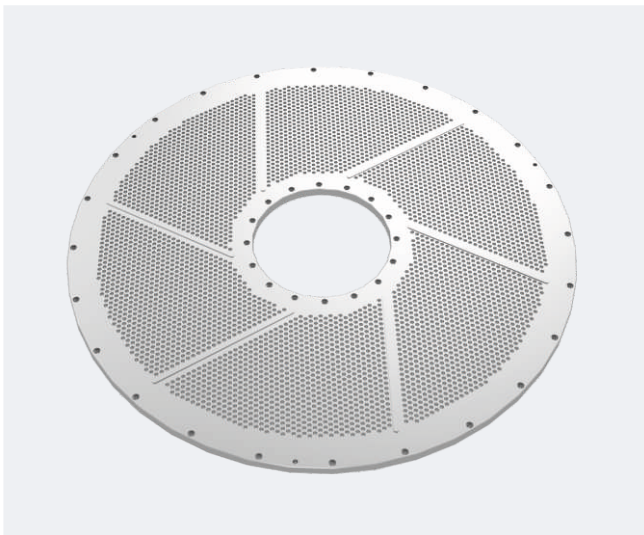

LCO Pulper Screen Plate

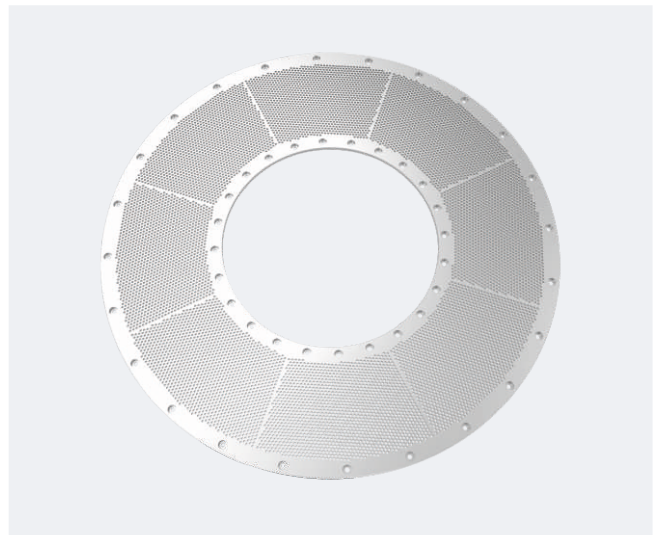

LC Pulper Screen Plate

Fast **Availability** for shorter **Downtime**

- Increased performance efficiency
- Long-term savings
- Reduced maintenance costs
- Timely delivery assurance



Modern World Class Manufacturing Setup



PARASON

Engineered Trust

Corporate office: Golden Dreams IT Park, 4th Floor,
E-27, Chikalathana MIDC, Beside Millennium Park,
Aurangabad (MH), India - - 431006

Tel. : +91 (0) 240 - 6644 444
Customer Service No: +91 96734 49922

Email: info@parason.com
Web: www.parason.com

FOLLOW US



Scan to watch videos

Note: Content subject to change without any prior notice | Power consumed may vary as per furnish combinations

"No part of this catalog may be reproduced or copied in any form or by any means (graphic, electronic or mechanical, including photocopying recording, taping, or information retrieval system) or reproduced on any disc, tape, perforated media or other information storage device, etc., without the written permission of the company, Breach of this condition is liable for legal action."